

TLA

Tuning-Set CTS-5-C

Manual



V1.30



TLA

Tuning-Set CTS-5-C

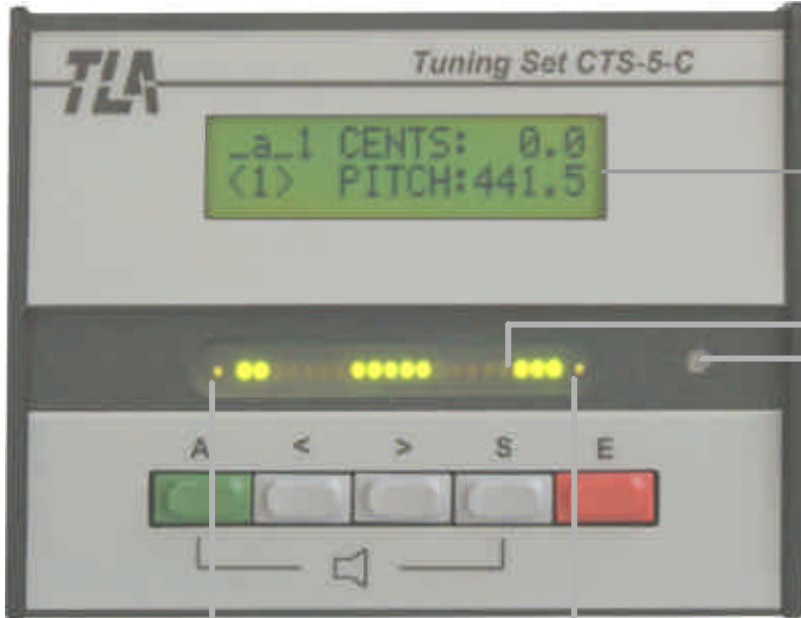

LC-display

Strobo-display

Inbuilt condenser microphone

Good/bad indicator



On/off slide switch

Socket for net adapter

Socket for external microphone

Sensitivity slide switch

Schéma d'emploi des accordeurs CTS-5-C

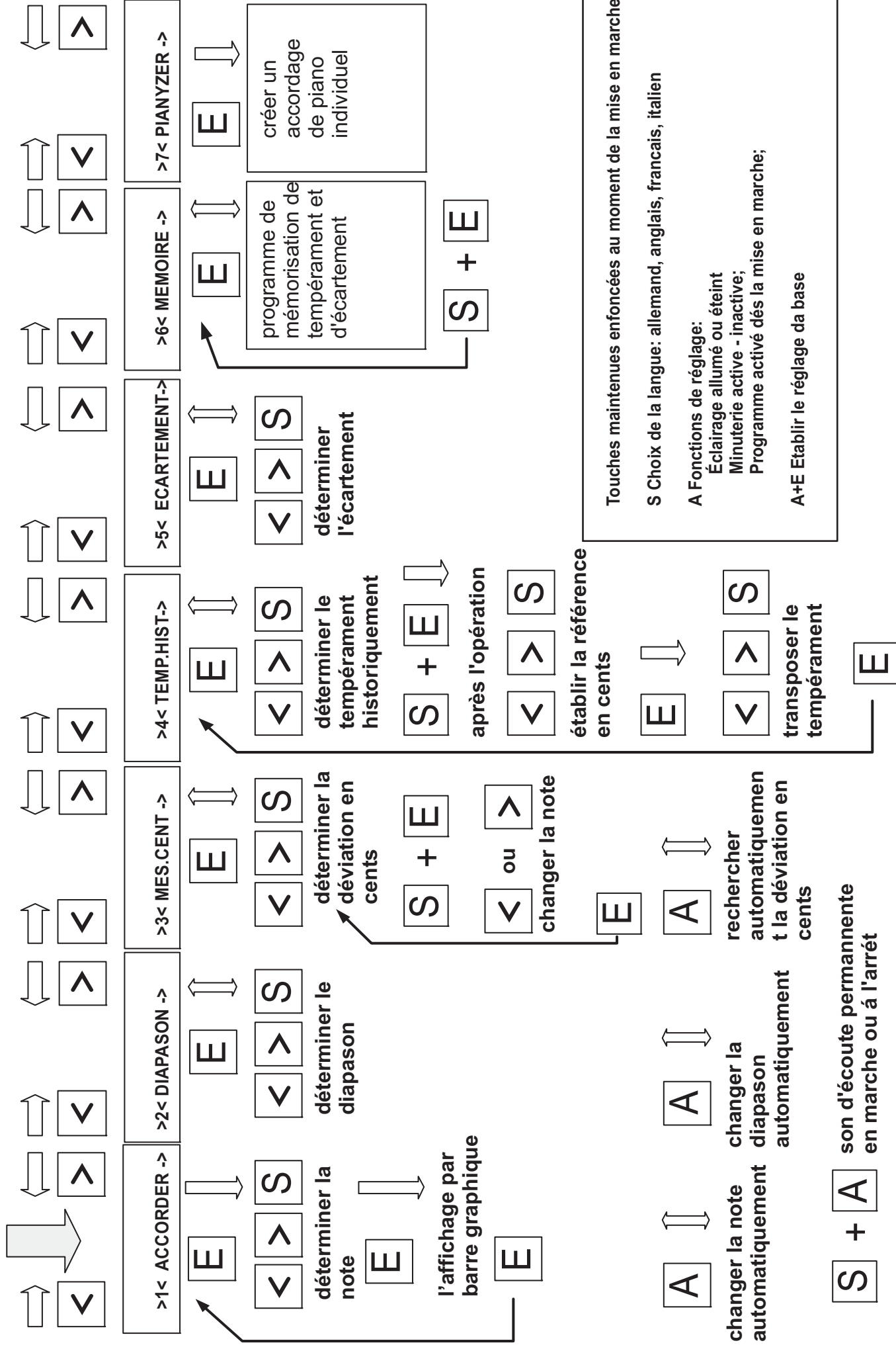



Diagram for modes of operation CTS-5-C

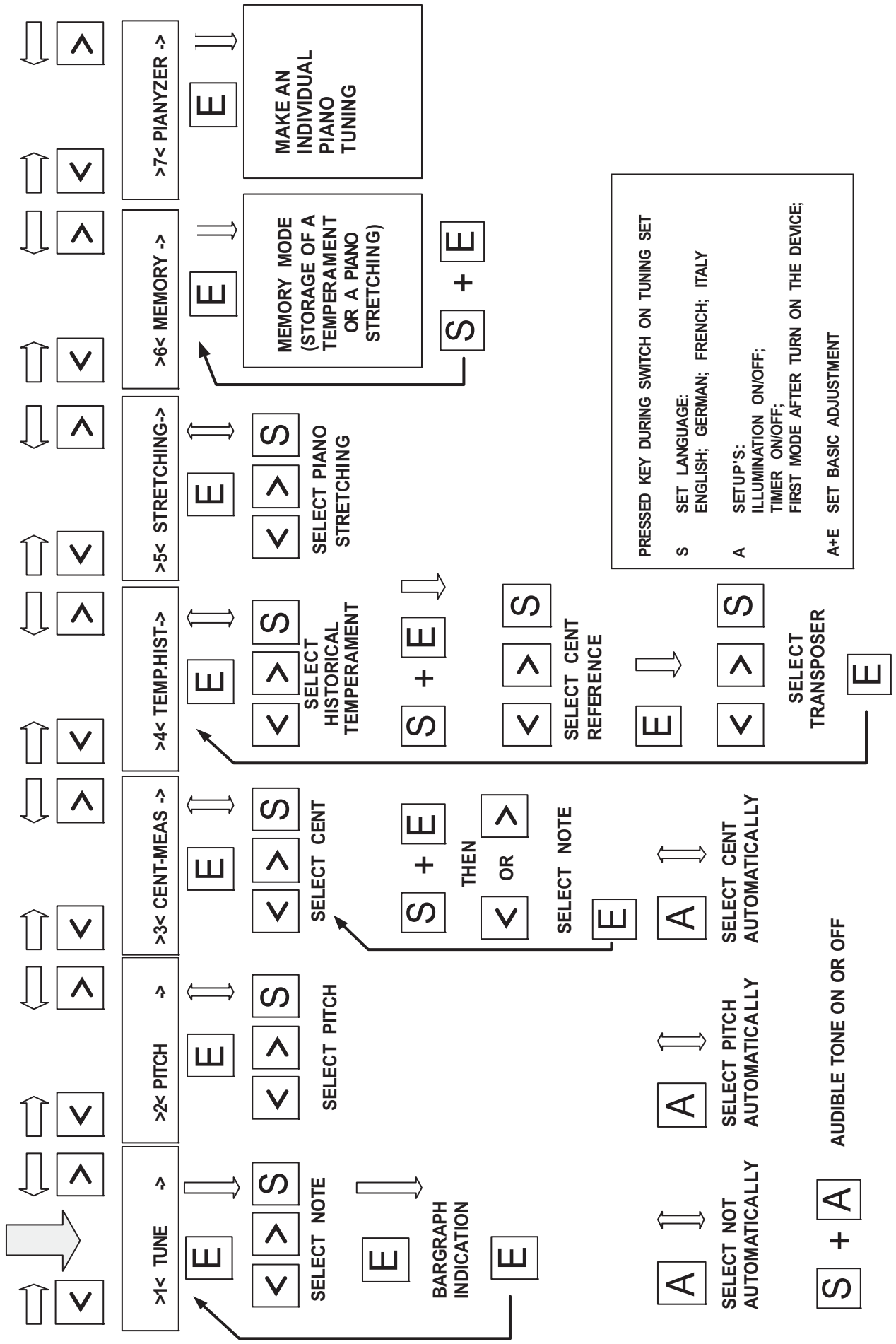
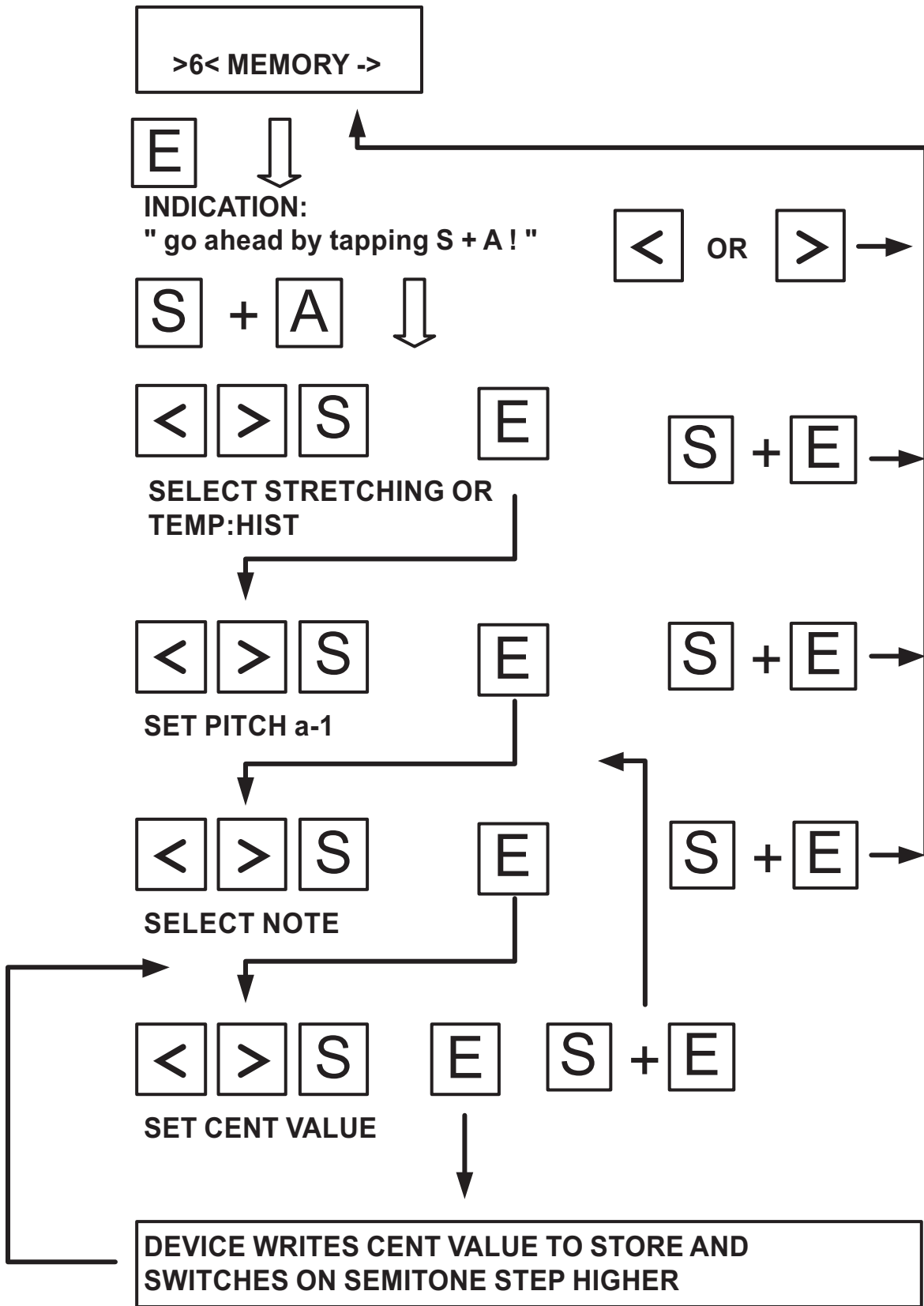
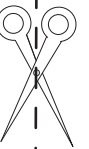
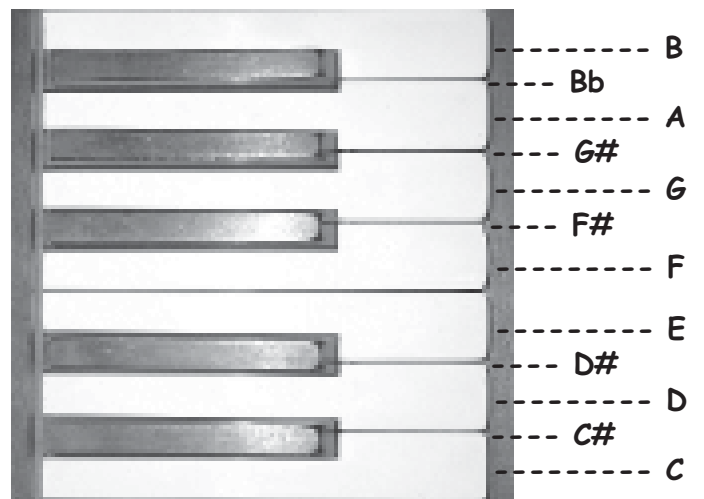
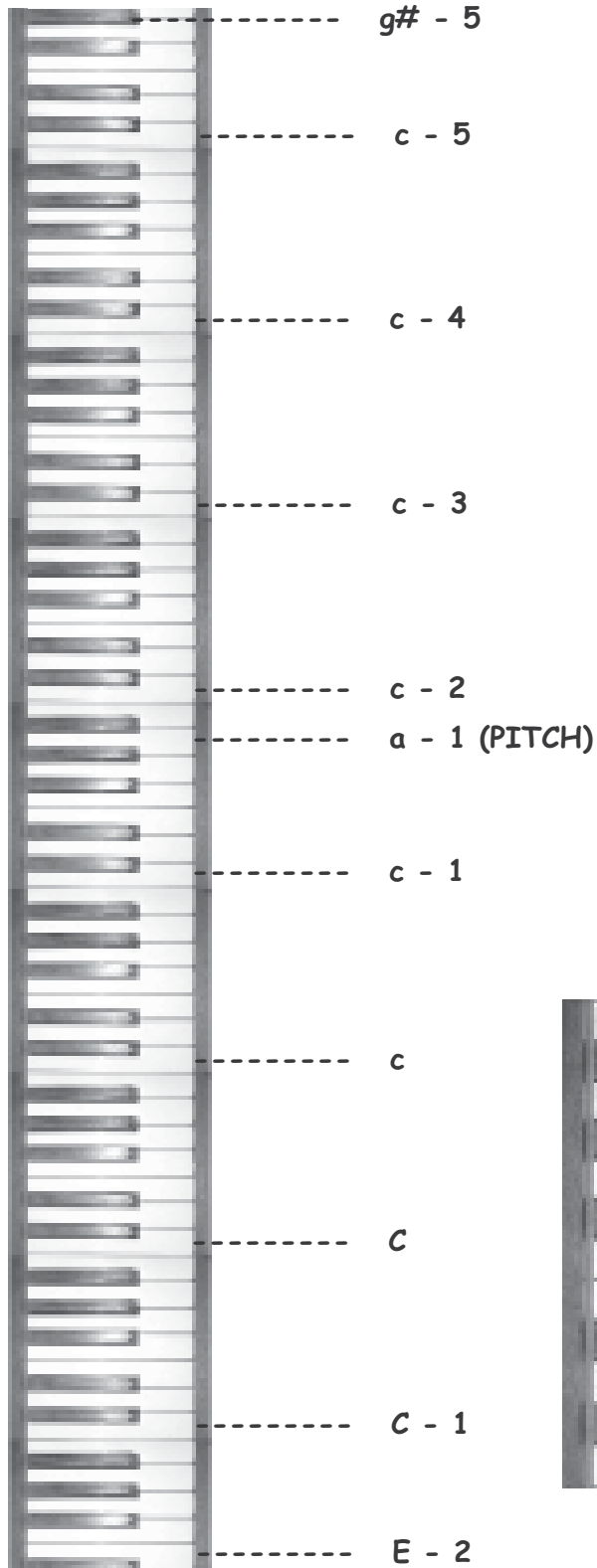

DIAGRAM FOR MEMORY MODE TUNING SET CTS-5-C



CTS-5-C NOTE INDICATION



Manual for Tuning Set CTS-5-C

Contents:

1	Initial Operations	2
1.1	Power	2
1.2	Switching on the Tuning Set	2
1.3	Selection of language for operator guidance	3
1.4	Introduction to the diagram for modes of operation	3
1.5	Erasing all inputs	4
1.6	Timer switch	4
1.7	Sensivity adjustment of the built in microphone amplifier	4
2	Operating Examples	4
2.1	Tuning, equal temperament, standard pitch 440 Hertz	4
2.1.1	Automatic note adjustment	5
2.1.2	Audible tone on/off	5
2.1.3	Bargraph Display	5
2.2	Presetting of the concert pitch	6
2.3	Measuring the concert pitch of an instrument	6
2.4	Measuring a tone's cent deviation	7
2.5	Piano tuning	7
2.6	Presetting of historical tempereaments	8
2.7	Memory	9
2.7.1	Operating scheme for memory mode	11
2.8	Combining individual modes	11
3	For all those who wish to learn more about Tuning Set ...	12
3.1	The equal temperament	12
3.2	The "cent" unit	12
3.3	The target frequency generation of CTS 5-C	12
3.4	The "cent"-values of the historical temperaments	13
3.4.1	The "cent"- relation function	13
3.4.2	The transposer	13
3.4.3	The adjustment of "cent relation function" and transposer	14
3.5	The "cent"- settings for piano tuning	14
3.6	The PIANYZER - how to make an individual piano tuning	15
3.6.1	How to create a stretching by the analysis of a piano (ANALYZER)	15
3.6.2	How to produce a piano stretching by entering of support values (Piano Editor)	17
3.6.3	Sample diagram of an piano stretching generated by the PIANYZER	17
3.6.4	Control scheme for using the PIANYZER	19
3.7	Special settings	20
4	Technical data Tuning Set CTS-5-C	21

1 Initial Operations

Congratulations on the purchase of your Tuning Set CTS-5. It will make the tuning of all kinds of musical instruments much easier. Part 1 of these operating instructions contains general information about the Tuning Set. Part 2 gives examples on how to learn the most important functions, and part 3 is for those of you who want to know all about this Tuning Set.

1.1 Power

The Tuning Set CTS-5-C can be operated with a plug-in transformer, or with battery power. Four batteries type Mignon 1.5 Volt are needed for approx. 6 hours of operation. When the batteries are empty, the LC-Display will show "LOW BATT.". For frequent battery operation a rechargeable set of NiMh cells, type Mignon 1.2 Volt, with a battery charger is advisable, and should be available at your local radio dealer. With 2500mAh NiMh cells, the Tuning Set should run approx. 14 hours on one charge.

REMARK: The socket for the plug-in transformer cannot be used as a socket for the battery charger. The batteries are automatically disconnected when the plug-in transformer is used.

WARNING ! CHECK THE POLARITY WHEN REPLACING BATTERIES.



1.2 Switching on the Tuning Set.

Switch on the Tuning Set with the slide switch on the right side of the Tuning Set. For approx. one second you see the program version, and then the following indication:

>1< STIMMEN ->

Should one of the next two indications appear, please go to the next paragraph.

>1< TUNING ->

>1< ACCORDER ->

>1< ACCORDARE->

1.3 Selection of language for operator guidance

Your Tuning Set can converse with you in English, French, German or Italian. Select the desired language as follows:

1. Turn off the Tuning Set.
2. While with the left hand depressing and holding the key "S", switch on the Tuning Set. Continue depressing the key "S" until you see this indicator.

LANGUAGE English

With the "< >" key you can select your desired language. Confirm it with the "E" key.

From then on the operator guidance language displayed by the Tuning Set is in the language you have selected. Switching the Tuning Set on or off does not change the language.

1.4 Introduction to the diagram for modes of operation

The Tuning Set is basically operated with the keys "<", ">", and "E". With the basic keys you can find your way through the included Diagram for Modes of Operation, like on a 'city map'. You are now, after turning on the Tuning Set, in the upper left hand corner, shown by the big black arrow.

With the keys "<" and ">" you can move to the left and right, and select one of the following modes:

- | | |
|-----------------|---|
| >1< TUNING | Tuning with the strobe display |
| >2< PITCH | Mode for standard pitch adjustment |
| >3< CENTMESS | Measuring or adjustment of a tone in cent |
| >4< TEMPERATURE | Mode for historical temperaments |
| >5< STRETCHING | Mode for tuning pianos |
| >6< MEMORY | Storage of one piano tuning or one historical temperament |
| >7< PIANYZER | Create an individual piano tuning |

With the key "E" you can move downward on the diagram. The selected mode is activated. If you press the key "E" again, you will enter the next user level or you will move upward, and are leaving the activated mode.

Selecting the wrong key or mode will not damage the Tuning Set. The stored temperatures and stretchings are protected and cannot be erased or changed by depression of a wrong key. In order to become acquainted with the Tuning Set, please play and experiment with the keys to your heart's content.

To quickly familiarize yourself with the Tuning Set, follow the examples given in part 2 on a musical instrument, and closely stick to the guidance.

Don't try to memorize the key sequences in the examples. Try to understand the operation of the Tuning Set by tracing the example steps on the diagram.

Note the arrow in the lower, right hand corner of the LC-Display:

When this arrow appears, the keys ">" and "<" are used for mode selection. You are then at the highest operating level of the diagram for operation modes.

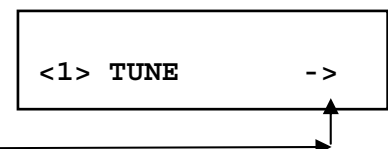

The text in the display then shows you what you may do with the keys "<" and ">", after you have depressed the key "E":

- | | |
|-----------------|--|
| >1< TUNING | Select a tone |
| >2< PITCH | Select the standard pitch |
| >3< CENTMESS | Measuring or adjustment of a tone in cent |
| >4< TEMPERATURE | Select a historical temperament |
| >5< STRETCHING | Select a piano stretching |
| >6< MEMORY | Storage of one piano tuning or one historical temperament. |
| >7< PIANYZER | Create an individual piano tuning |

Pressing the key "E" makes the arrow disappear. The Tuning Set is now in the selected mode. With the keys "<" and ">" you can now carry out your previously selected mode.

By pressing the key "E" again you enter the next user mode.

If the arrow will reappear, you have left the mode. With the keys "<" and ">" you may select a new mode of operation. The input or adjustment made within a mode will remain intact after you exit the mode.

A special case is the mode number 6 (MEMORY). This mode you only can leave by tapping both keys "S" and "E".

All inputs or adjustments made in the operation modes will not be erased by turning the Tuning Set on or off. One exception is the standard pitch, which automatically resets to a1 after the Tuning Set is turned on.

1.5 Erasing all inputs

Should you have stumbled in your first walking trials, and put in a non desired setting, you may return to the original settings contained in the Tuning Set upon delivery:

Standard pitch:	440 Hz
Temperature:	Equal Temperament
Stretching:	None
Transpose Function and Cent Relate Function:	Off

Operate as follows:

Turn off the Tuning Set. Simultaneously depress keys "A" and "E" with the left hand until you have switched on the Tuning Set with your right hand. Continue holding the keys until the LC-Display indicates:

1.6 Timer switch

A timer was installed in the Tuning Set, to save battery power. If you don't use the set for twenty minutes, it will automatically turn off. Before shutdown it will set off several short accoustical signals. This allows you to prevent shutdown by depressing one of the five keys. If the Tuning Set automatically turned off, you may restart it with the on/off lever on the right side by switching it off and on. You may turn off the timer completely (see chapter 3.7).

1.7 Sensivity adjustment of the built in microphone amplifier

You may reduce the sensitivity of the built-in microphone amplifier with the slide switch located on the right side below of the Tuning Set. You may need this especially for the low tones of a piano. The optimal setting of this switch and the optimal placement of the Tuning Set must be found during the tuning process.

2 Operating Examples

2.1 Tuning, equal temperament, standard pitch 440 Hertz.

Normally a musical instrument is tuned in standard equal temperament. The standard concert pitch a', on which the complete level of pitch is based, is often tuned to a frequency of 440 Hertz. This is the mode with the fewest operational steps. Therefore let us take this mode for our first example.

Switch on the device:

Display:

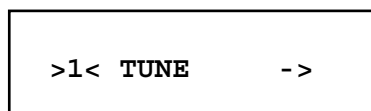

Tap key "E" briefly:

The device operates now in tune mode.

Display:

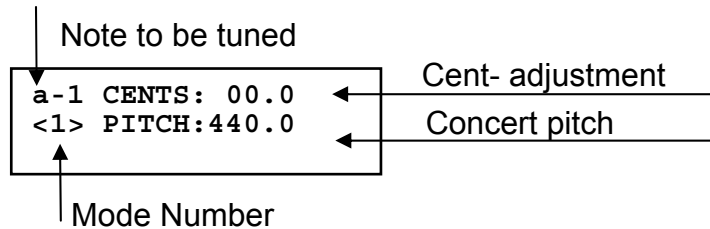

Now strike the tone a' on your instrument. Two green illuminated sets of beads appear on the stroboscopic display. The beads move to the left if the tone is too low, or to the right if the tone is too high. As the tone approaches the desired pitch, the movements will slow down. At the correct pitch the beads will stop moving. You can recognize larger frequency deviations, when one of two green dots on the left or right of the stroboscopic display is lit. Depending on whether the desired tone is too high or too low, either the right or the left dot will be lit continuously. If neither of these dots shines, the tone played is at the desired pitch of less than 4 cent.

For tuning the next higher semi-tone, tap key ">" briefly. This raises the CTS-5-C by one semi-tone.

Similarly, if you tap key "<", you lower the CTS-5-C by one semi-tone.

Constantly depressing key "S" and simultaneously tapping key ">" briefly, will raise the device by one octave.

Constantly depressing key "S" and simultaneously tapping key "<" briefly, will lower CTS-5 by one octave.

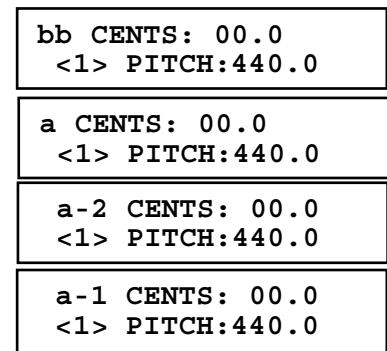

If you depress either key "<" or ">" constantly, the desired function will repeat itself every 0.5 seconds.

2.1.1 Automatic note adjustment

Now depress key "A":

The device now automatically follows the tone level of the played tone. The automated switching was intentionally limited to two semi-tone steps, to avoid undesired tuning of partial tones. For the same reason the automatic mode is not available for the two lowest octaves.

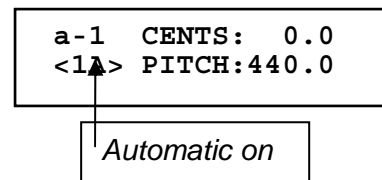

Again depressing key "A" switches off the AUTOMATIC MODE.

2.1.2 Audible tone on/off

Activate tone: When you keep the "S" key pressed and tap "A", you will hear the tone at the currently desired frequency.

Release both keys.

Deactivate tone: Keep "S" key pressed and tap "A" again.

Increase volume: While keeping "S" pressed, press "A" twice again for higher volume.

2.1.3 Bargraph Display

In the tuning mode, you can switch between the bar graph and the concert pitch display with the "E" key.

Press the "E" key. When you now strike the tone a1 on your instrument, the arrow points to the right, if the tone played is too high, and to the left, if it is too low.

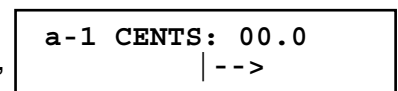

2.2 Presetting of the concert pitch

The standard pitch of the CTS-5 may be adjusted from 380.0 to 470.0 Hertz.

Display after switching on the CTS-5:

Press key ">" once.

Press key "E"

By tapping key ">" you can raise the pitch by 1/10th Hertz

By tapping key ">" you can lower the pitch by 1/10th Hertz

If you constantly depress key "S" and simultaneously tap key ">", you will raise the pitch by one Hertz

If you constantly depress key "S" and simultaneously tap key ">", you will raise the pitch by one Hertz

If you wish to adjust the standard pitch to 443.2, for example, you tap keys "S" and ">" three times, and the key ">" twice.

To start tuning with the adjusted standard pitch you must now leave the standard pitch program and activate the tuning program. The adjusted standard pitch will be taken over into the tuning program.

Press "E"

Press "<" once

Press "E"

Now you may start tuning with the newly adjusted standard pitch

2.3 Measuring the concert pitch of an instrument

Enter, like in the above example, into the pitch mode.

Display for instance:

Tap key "A".

When you now strike the tone a1 on your instrument, the standard pitch program of the device starts to adjust to the played tone.

The tone to be measured must be played until the stroboscopic display almost or completely comes to a stop (tones of short duration must be stricken repeatedly). Now press the key "A" again, preferably while the tone is still heard. This will turn off the automatic mode.

<1> TUNE	->
<2> PITCH	->
a-1 <>PITCH <2> PITCH:440.0	
a-1 <> PITCH <2> PITCH:440.1	
a-1 <> PITCH <2> PITCH:440.0	
a-1 <> PITCH <2> PITCH:441.0	
a-1 <> PITCH <2> PITCH:440.0	
a-1 <> PITCH <2> PITCH:443.2	

<2> PITCH	->
<1> TUNE	->
a-1 CENTS: 0.0 <1> PITCH:443.2	

a-1 <>PITCH <2> PITCH:440.0
a-1 <>PITCH <2A> PITCH:440.0

Automatic on

If necessary, adjust the CTS-5-C to the correct tone, by tapping the keys "<" or ">", until the stroboscopic display is standing still, while the tone is being played. Only then the CTS-5 is adjusted to the correct value.

You may now read the measured standard pitch on the LC-Display.

2.4 Measuring a tone's cent deviation

The unit of measure CENT is used in accoustics for the deviation of a tone from a basic frequency. A cent is about one hundredths of a semi-tone step. The exact value is described in Part 3 of these Operating Instructions.

Please use mode number 3 "CENT MEAS" for cent measuring. Its procedure is the same as that for measuring the standard pitch.

The cent-adjustment of the CTS-5 always relates to the previously adjusted tone and concert pitch.

Remark to "CENT-MEAS" mode: To adjust the note without leaving this mode, operate like this: Keep "S" pressed and shortly tap „E“. From now on, you can adjust the note with "< >".

Tap "E". From now on, you adjust the cents again with "< >"

2.5 Piano tuning

First things first: We cannot overemphasize the fact that piano tuning requires experience. If it is done without the necessary knowledge and skills, the piano may be irreparably damaged. In one tuning, a piano should never be raised or lowered by more than 30 cent.

When tuning pianos and grand pianos, the stretching of tune has to be considered for various reasons, i.e. that in deviation from the standard tune, high tones have to be tuned higher, and bass tones lower. We will discuss this further in Part 3 of the Operating Instructions. The Tuning Set CTS-5-C may be adjusted so that, based on stretching diagrams, which are incorporated in the CTS-5-C program, these deviations or stretchings are automatically considered.

Several stretchings are available in the Tuning Set. Four are permanently programmed. The stretching number 5 and number 6 you can enter yourself, using program 6 (MEMORY) and program 7 (PIANYZER) You may find the diagrams of the four permanently programmed stretchings in Part 3 of the operating instructions.

The choice of the optimal stretching depends on various parameters of the instrument to be tuned. Another important consideration is the preference of the musician.

The four built-in stretchings are the result of trials, during which various pianos were tuned by ear, and subsequently measured. The stretching most suitable for your requirement must be tried by you first, considering that the weak and middle stretching is more suitable for pianos with large measure (concert grand piano). We recommend that in your first attempts you try the Stretching Number 3 (MODERATE). For this, the Tuning Set is used as follows:

Turn on the device

Tap ">" 4 times

Tap "E"

<1> TUNE	->
----------	----

<5> STRETCHING	->
----------------	----

NO STRETCHING	
<5> Number	00

Using keys "< >" you may select one of the following stretchings.

- | | |
|---------------------------|--|
| Number 1 (VERY SLIGHT) | Bass and Descant stretched slightly. |
| Number 2 (SLIGHT) | Bass and Descant stretched. |
| Number 3 (STR.MODERATE) | Bass and Descant stretched heavily. |
| Number 4 (STR.PRONOUNCED) | Bass weak, center portion stretched heavily. |
| Number 5 (MEMORY) | Self stored stretching |

In this example we will obtain Stretching Number 3 (STR.MODERATE): Press ">" 3 times

Press "E"

Press "<" 4 times

Press "E"

```
STR.MODERATE
<5>  NUMBER  03
```

```
<5> STRETCHING ->
```

blinking

```
STR:MODERATE
<1> TUNE      ->
```

```
a-1 CENTS:  00.0
<1> K-TON:440.0
```

```
b-2 CENTS:   0.1
<1> PITCH:440.0
```

Now you may start tuning. Start with tone a' and tune all three strings. Continue with b', h', c", etc. At one of the higher tones you may see the following display (for example):

The Tuning Set is now considering preselected stretching. Any deviation from standard tune is indicated in CENTS on the lower display line.

After you have finished tuning the descant, start tuning downward beginning with g#. The deeper tones will automatically be tuned lower according to the preselected stretching. The deviation again shows on the lower line of the display.

In this particular mode, the cent-adjustment follows a function, which is dependent on the octave range. It is therefore very important to ascertain the correct octave range on the Tuning Set. Errors can be avoided by progressing in semi-tone steps.

2.6 Presetting of historical temperaments

Friends of historical instruments can use TUNING SET CTS-5-C for 27 different historical temperaments. The last one may be programmed by yourself (see memory mode).

In the following example the instrument is tuned to "WERCKMEISTER III":

Switch on the device:

Press ">" 3 times

Press "E"

Using keys "<" or ">" you may now select a historical temperament. To select "Werckmeister-III" press "<" until you receive the following indicator:

press "E"

```
>1< TUNE      ->
```

```
>4< TEMP.HIST.->
```

```
EQUAL_TEMPERMNT
>4<  NUMBER  00
```

```
WERCKMEISTER_III
>4<  NUMBER  00
```

```
>4< TEMP.HIST.->
```

Press "<" 3 - times

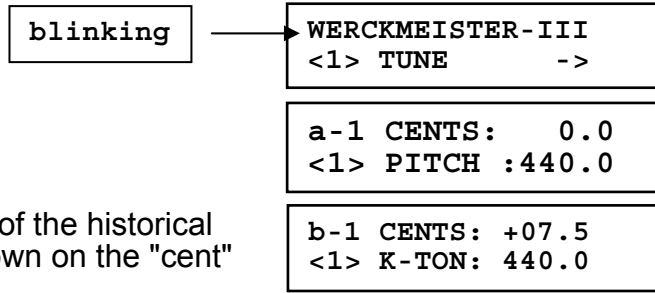

Press "E"

Now you may start tuning. The cent-deviation of the historical temperament to the equal temperament is shown on the "cent" field.

Cent deviations of the various historical temperaments see chapter 3.4

2.7 Memory

To refresh your already considerable knowledge of the CTS-5-C

Stretchings are functions, which encompass the entire tone range of an instrument. For each tone (spanning its entire range) in the Tuning Set there is a cent value. One stretching therefore contains storage space for a total of 8*12=96 CENT values. You may input one such stretching into the Tuning Set. On the other hand, a temperament relates only to the 12 semi-tones of an octave, and therefore only contains 12 cent values. These cent values are then repeated for each octave, considering that the cent deviation for the tone "a", as program-necessitated, is always zero (See Function of cent Relationship and Transposition in Part 3.4 of the operating instructions). You may input one such temperament into the CTS-5-C.

You can combine the stored stretching with temperaments, or built-in functions, as you please. If you select a temperament and a stretching at the same time, the Tuning-Set will add the temperament cents to those of the stretching. Your data will be stored permanently, even if you remove the batteries.

To quickly familiarize yourself with the memory functions, follow the examples on a musical instrument. Use the included "Diagram for Memory Mode" to find your way through the menus.

Switch on the Tuning Set and select mode Number 6 "MEMORY ->". After tapping key "E" a rotating message will appear:

Go ahead by tapping S + A !

You can still leave the memory mode without changing the memory, by tapping key "<" or ">". You can leave the memory mode at any time, by pressing keys "S" and "E" simultaneously. This is herein after referred to as ("S+E").

Go ahead by pressing key "S" and "A" simultaneously:

With "< >" keys now you determine what kind of memory you intend to use, a stretching or a temperament.

SELECT <>
STRETCHING

Now press "E" to if you intend to store a stretching. The device enters in pitch mode and will automatically switch to the note "a-1".

a 1 <> PICH
<6> PICH: 440.0

If you intend to store a already existing stretching of a music instrument, you now have to align the Tuning Set to the concert pitch of your instrument (as already described in chapter 2.3). This should be done very carefully, because the cents of the stretching will relate on this concert pitch.

Press "E", the device switches to tune mode, and the note adjustment goes to its deepest note.

Now, select with "<>" keys the deepest note to be stored, for example A₂.

Press "E", the device switches to "cent measurement mode". Indication for example:

Now, play A-2 on your instrument and make a cent measurement (like chapter 2.4)

If you are ready, press "E" to store the cent value. This is confirmed by a short beep.

After this, the note adjustment will switch to the next higher note. Join now to measure the cent value of the next note.

```
A 2 CENTS:  0.0
<6> <> NOTE
```

```
A 2 CENTS: -18.3
<6> <> CENT
```

```
A 2 CENTS: -18.3
<6> <> CENT
```

```
! DATA STORED !
```

```
B 2 CENTS:  0.0
<6> <> CENT
```

Repeat the last two steps, until you have stored all notes of your instrument.

When you are finished, it makes sense to confirm the stored stretching. With "S+A" you go back to "tune mode". With "< >" you can confirm all the cents you have stored. After pressing "E" you may correct a single cent value.

If you are ready you may leave the "memory mode" by tapping "S+E" twice or simply turn off the device.

Now, the stored stretching is active in the Tuning Set. By selecting "tune mode" you will see this indication:

blinking

```
MEMORY STRETCHING
<1> TUNE
```

If you intend to return to a firmly stored stretching, you may select it according to the chapter 2.5 or 2.6.

The storage of a temperament is similar as to store a stretching. To summarize:

After entering "memory mode", you have to choose the option "TEMP.HIST" instead of "STRETCHING".

```
AUSWAHL <>
TEMP.HIST.
```

Press the "E" and operate the concert pitch alignment carefully. If you want only enter a theoretical temperament, you may skip this point.

Enter "tune mode" by pressing „E“ („<> NOTE“)

When entering this mode, the device automatically switches to the note bb-1. The entry of the note "a" is locked and the corresponding cents are set to zero automatically. This is technically necessary (see chapter 3.4). If you still try to select "a" the note will be skipped and "a = reference" is indicated.

To store the cents of a temperament, operate in the same way as to store a stretching.

3 For all those who wish to learn more about Tuning Set ...

3.1 The equal temperament

The Equal Temperament is the most frequently used temperament, it is the basic tuning of CTS-5. The following example shows its mathematical theory.

Given that standard pitch a' is 440.0 Hertz, then oscillations of the chromatic semi-tone steps are calculated as follows:

$$\begin{aligned} bb' &= 440,00 \text{ Hz} * \sqrt[12]{2} = 466,16 \text{ Hz} & 12 & 2 = 1,0594631 \\ b' &= 466,16 \text{ Hz} * \sqrt[12]{2} = 493,88 \text{ Hz} & & \text{etc.} \end{aligned}$$

When the standard pitch a' is 442.00 Hertz:

$$\begin{aligned} bb' &= 442,00 \text{ Hz} * \sqrt[12]{2} = 468,28 \text{ Hz} \\ b' &= 468,28 \text{ Hz} * \sqrt[12]{2} = 496,13 \text{ Hz} & & \text{etc.} \end{aligned}$$

3.2 The "cent" unit

Cent is a value for proportions of frequencies. A semi- tone is geometrically divided into 100 parts (= 100 cent). The following example will show how the cent-value is defined mathematically. The frequency of oscillations is given with 440.0 Hertz and is to be increased by 1 cent:

$$440.00 \text{ Hz} * \sqrt[1200]{2} = 440.26 \text{ Hz}$$

The frequency of oscillation is given with 440.00 Hertz is to be increased by 5 cent.

$$440.00 \text{ Hz} * \sqrt[1200/5]{2} = 441.27 \text{ Hz}$$

The frequency of 440.00 Hertz is to be increased by 100 cent (= 1 semi-tone).

$$440.00 \text{ Hz} * \sqrt[1200/100]{2} = 440.00 \text{ Hz} * \sqrt[12]{2} = 466.16 \text{ Hz}$$

The frequency of 466.16 Hertz is to be lowered by 100 cent (= 1 semi-tone).

$$466.16 \text{ Hz} : \sqrt[1200/100]{2} = 466.16 \text{ Hz} : \sqrt[12]{2} = 440.00 \text{ Hz}$$

3.3 The target frequency generation of CTS 5-C

Tuning Set CTS-5 contains a microprocessor which generates the nominal frequency (f) according to the following equation.

$$f = \frac{k}{4} * 2^{o + \frac{n}{12} + \frac{c}{1200}}$$

c:	"cent" - presetting	(+99.5)
n:	number of tone	(a=0, bb=1, ... g#=11)
k:	standard pitch presetting	(380.0 ... 470.0 Hz)
o:	octave	(1=A2/110Hz, 2=A1/220Hz, ... 6=a4/3520Hz)

3.4 The "cent"-values of the historical temperaments

See table at the end of this manual.

3.4.1 The "cent"- relation function

All temperament tables in the Tuning Set (including the self stored one) are calculated so that the cent deviation of the tone "a" is zero. We may say that "a" is the "cent relation tone". Sometimes other cent relation tones will be required. If you use a cent relation tone other than "a" on the Tuning Set, every cent deviation value in the current temperament table will be increased or decreased by the same value, so that the cent relation tone will have the cent deviation value zero.

Example:

The current temperament is "Kirnberger III", the selected cent relation tone is "a" (i.e. cent relation function is not active):

a	bb	b	c	c#	d	d#	e	f	f#	g	g#
0	+6.5	-1.5	+10.5	+0.5	+3.5	+4.5	-3.5	+8.5	+0.5	+7.0	+2.5

By using cent relation tone = "c" all cent values will be lowered by 10.5 cent.

a	bb	b	c	c#	d	d#	e	f	f#	g	g#
-10.5	-4.0	-12.0	0	-10.0	-7.0	-6.0	-14.0	-2.0	-10.0	-3.5	-8.0

3.4.2 The transposer

With the transposer you may transpose the selected temperament into any key. For example, if you need to transpose from key "a" to key "c", all cent deviation values of the temperament table have to be rotated three semi-tones to the right.

Example: transposition "a" to "c" (cent relation tone = "a"),

temperament "Kirnberger III"

Cent deviation table of "Kirnberger III"

a	bb	b	c	c#	d	d#	e	f	f#	g	g#
0	+6.5	-1.5	+10.5	+0.5	+3.5	+4.5	-3.5	+8.5	+0.5	+7.0	+2.5

first, the table will be rotated by 3 semi-tone steps to the right

a	bb	b	c	c#	d	d#	e	f	f#	g	g#
0.5	+7.0	+2.5	0	+6.5	-1.5	+10.5	+0.5	+3.5	+4.5	-3.5	+8.5

The cent relation function then sets the cent relation tone (in this example tone "a") to 0, lowering every cent value by 0.5 cent.

a	bb	b	c	c#	d	d#	e	f	f#	g	g#
0	+6.5	+2.0	-0.5	+6.0	-2.0	+10.0	0	+3.0	+4.0	-4.0	+8.0

The instruction of how to use the transposer is found in chapter 3.4.3.

3.4.3 The adjustment of "cent relation function" and transposer

Use mode 4 "TEMP. HIST" for this. First select a temperament. The display will be similar to the following:

:

Press keys "S" and "E" briefly and simultaneously. Select the cent relation tone with the keys "<" or ">". Then press key "E":

Select with "< >" the transposer as you like.

Press "E".

Select with "< >" mode "TUNE"

After pressing key "E" you can start tuning.

```
WERCKMEISTER-III
>4<  NUMMER  24
```

```
CENT REF.:  _A_
>4<
```

```
TRANSP. A --> A
>4<
```

```
>4< TEMP.HIST->
```

```
>1< TUNE->
```

```
Blinking indicator:
WERCKMEISTER-III
CENT-REF  _C_
TRANSP A --> C
```

3.5 The "cent"- settings for piano tuning

Striking a string on a piano produces a tone consisting of several harmonics which are not in tune with their fundamentals.

For example, the tone produced by a piano string for tone a' can consist of a 440 Hz fundamental, with a second harmonic at 881 Hz and a fourth harmonic at 1768 Hz. If the partials had a harmonic proportion of frequencies to each other, the second harmonic would have a value of 880 Hertz and the fourth harmonic 1760 Hertz. However, in our example the second harmonic is one Hertz and the fourth harmonic 8 Hertz higher than demanded in theory.

This is known as the "Inharmonicity" of a piano string. It is caused by the stiffness of the string and can be different from instrument to instrument. This inharmonicity explains why, on a piano, the bass has to be tuned lower than the theoretical frequency and the descant higher.

The four different stretchings of the octaves have been developed through extensive tests with various upright and grand pianos. The diagrams of these stretchings may be found on the last page. See also chapter 3.6 (creating individual piano tunings using the PIANYZER).

In the lowest octave (A 2 to G#) the Tuning Set responds to the fourth harmonic, and in the octave (A 1 to g#) to the second harmonic. This is the reason for the two discontinuities in the graphs.

3.6 The PIANYZER - how to make an individual piano tuning

Using the „Pianyer“ (Piano Analyzer) you get more beautiful piano tunings. Here the stretching of the instrument will be optimized individually.

The stretching can be created in two ways.

1. An analysis of the piano to be tuned (ANALYZER).
2. By entering cents for certain specific tones (EDITOR).

The stretching is stored as stretching number 6. With firmware 1.30 this 6 stretching options are available

Number 1 (VERY SLIGHT)	Bass and Descant stretched slightly.
Number 2 (SLIGHT)	Bass and Descant stretched.
Number 3 (STR.MODERATE)	Bass and Descant stretched heavily.
Number 4 (STR.PRONOUNCED)	Bass weak, center portion stretched heavily.
Number 5 (MEMORY)	Self stored stretching
Number 6 (PIANYZER)	Produced by pianyer

3.6.1 How to create a stretching by the analysis of a piano (ANALYZER)

If you have practiced, you need for the analysis less than 5 minutes. Due to the interference-free analog strobe display you get a safe, reproducible result.

By measuring the cent-deviation of certain partials of 5 special tones, reference values are determined. (See the sample diagram of an individual piano stretching at the end of chapter the capter). Based on these support-values, an optimized stretching will be calculated and stored. To this end, the device makes all settings automatically. Important! For all measurements, please damp with a felt wedge the string chorus so, that sounds just one string.

To work with the Analyzer, do the following:

After switching on the unit, use the „<>“ buttons to select the option „PIANYZER“ and press „E“ button.

```
<7> PIANYZER
```

Select the option „ANALYZER“ and press “E” again.

```
SELECT <>  
ANALYZER
```

Select the highest tone of your piano which has a 2 string chorus and press “E”

```
2-STRING CHOIR  
_d_
```

Select the highest tone of your piano which has a 1 string chorus and press “E”.

```
1-STRING CHOIR  
G#_1
```

Play the note "a-1" to measure the concert pitch of your instrument and use the "<>" buttons to align the tuner. (See also capter 2.3 of the manual) or you already can tune the chorus of "a-1" to your desired pitch.

```
_a_1 <> PITCH  
<7> PITCH:440.0
```

By pressing the "E " you are starting with the measurement of the individual partials of the piano-analysis.

The indicator for this is structured as follows:

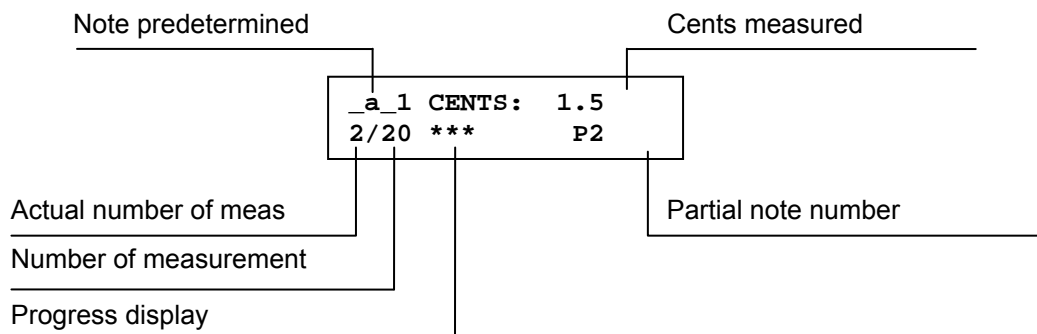

Start now with the measurements (you now measure the second partial of a-1. To do this, play the note which is automatically adjusted by the tuner (right now a₁) and align the tuners frequency until the movement of the strob display is stopped.

For fine adjustment use the "<>" buttons. For rough adjustment, you hold the "S" button and tap one of the keys "<>". Pressing "A" starts an automatic scan. The audible tone can be used also.

Press „E“.

Play the specified note (for the moment again a₁, since you now measure the 3rd partial of a-1) and align the tuner again. Press "E".

_a_1	CENTS:	3.5
3/20	**	P3

Play the specified note (for the moment again a₁, since you now measure the 4rd partial of a-1) and align the tuner again. Then press "E". The tuner will now continue to the next note. It then emits a short beep and for 1 second „next note“ is indicated.

_a_1	CENTS:	6.0
4/20	*	P4

Play the specified note (for the moment again a₂, since you now measure the fundamental tone of a-2) and align the tuner again. Press "E".

_a_2	CENTS:	2.5
5/20	***	P1

Certainly, you now know how the device pretends the operating steps. Now perform all measurements.

Important note: When the instrument is grossly out of tune, immediately after the tuner changes the note, you should align the actual tone to the tuner using a tuning hammer. This is necessary because the inharmonicity of the piano string depends on its tension. This, however, only be carried out immediately after the change of note. So just before the measurements 5 / 9 / , 13 / and 17/

After the last measurement you get this display. This are eight cents-values (support values), that were determined automatically on the basis of previous measurements.

-26	-16	-8	-2
0	3	11	36

Press "E". The device calculates the piano stretching and stores them, and automatically jumps to "tune" mode. Then it goes on, as described in Section 2.5 of the manual for CTS-5-C.

flashing

PIANYZER STRETCH
<1> TUNE

Note: Within the "ANAYZER"- procedure, you can back step by holding "S" button while tapping "E" button.

3.6.2 How to produce a piano stretching by entering of support values (Piano Editor)

The tones with the cent's for calculating the stretching, the sake of simplicity, will be referred to as "support note". Using the piano editor, the cents of the support-notes, you can enter by hand, rather than be determined by the analyzer (see sample diagram at the end of the chapter).

Note: The piano editor allows you to edit the cents of the supporting notes, which were previously generated by the piano analyzer.

To work with the Editor, do the following:

After switching on the unit, use the „<>“ buttons to select the option „PIANYZER“ and press „E“ button.

```
<7> PIANYZER
```

Select the option „EDITOR“ using the „<>“ and press “E” again.

```
SELECT <>
EDITOR
```

Select the highest tone of your piano which has a 2 string chorus and press “E”

```
2-STRING CHOIR
_d__
```

Select the highest tone of your piano which has a 1 string chorus and press “E”.

```
1-CHOERIG >>>
G#_1
```

Play the note "a-1" to measure the concert pitch of your instrument and use the "<>" buttons to align the tuner. (See also capter 2.3 of the manual) or you already can tune the chorus of "a-1" to your desired pitch.

```
_a_1 <> PITCH
<7> K-TON:440.0
```

By pressing the "E " you are starting to enter the cents of the “support notes.

Using the „<>“ buttons, you enter the cents of the „support-note“ which is predefined by the tuner. With the „E“ you may switch to the next „support-note“.

```
a2 CENTS: 2.9
SUPPORT-NOTE: 6
```

If you have entered the cents for all the "support-notes" , you will get i.e. the following indicator.

```
-26 -16 -8 -2
0 3 11 36
```

Press “E”. The device calculates the piano stretching and stores them and automatically jumps to “tune” mode. Then it goes on, as described in Section 2.5 of the manual for CTS-5-C.

flashing

```
PIANYZER STRETCH
<1> TUNE
```

Note: Within the “EDITOR”- procedure, you can back step by holding “S” button while tapping “E” button.

3.6.3 Sample diagram of an piano stretching generated by the PIANYZER

See next page...

Diagram of a piano stretching that was generated with the Pianyzer

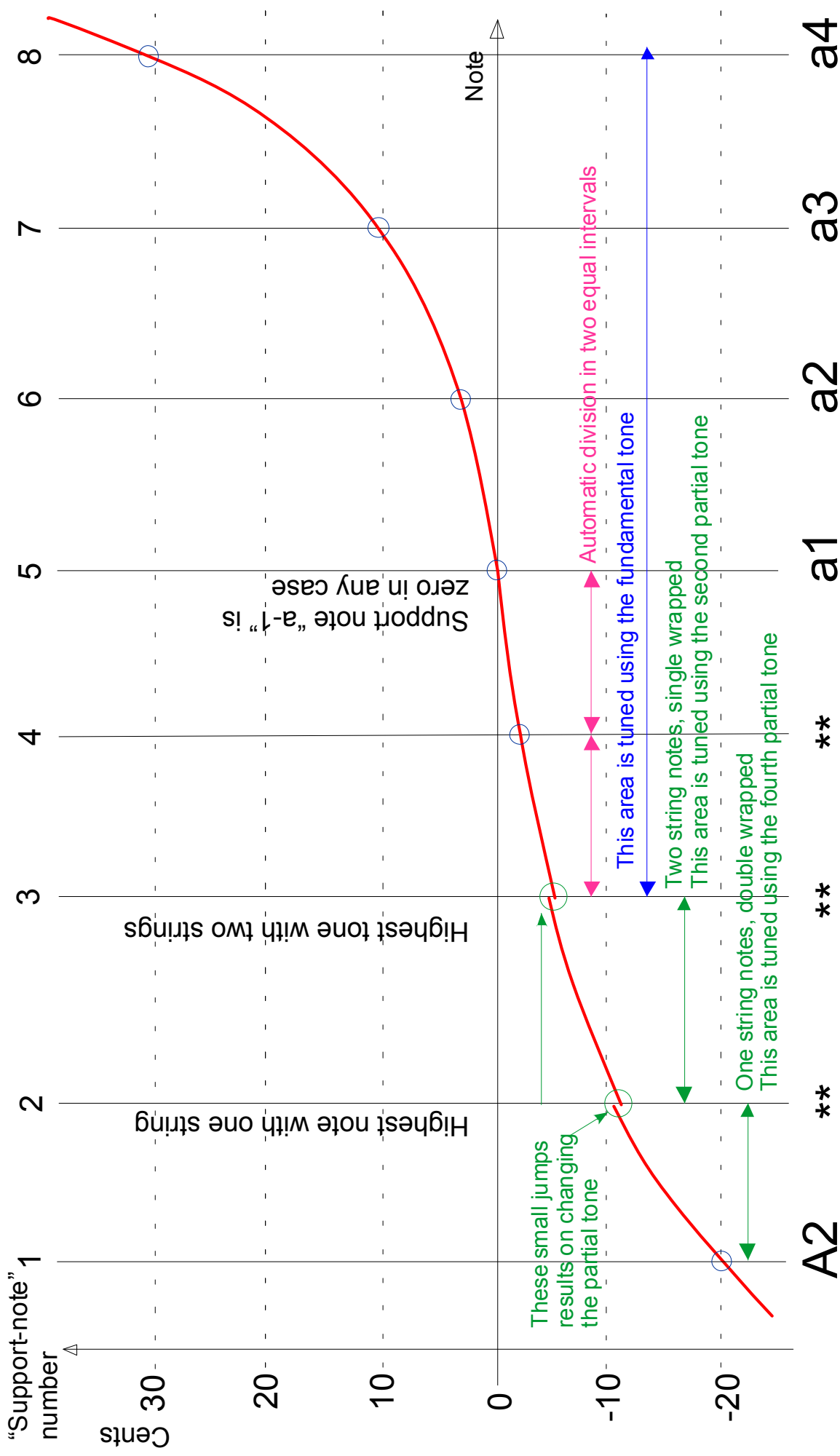

**These "support-notes" depends on the way of the strings arrangement

3.6.4 Control scheme for using the PIANYZER

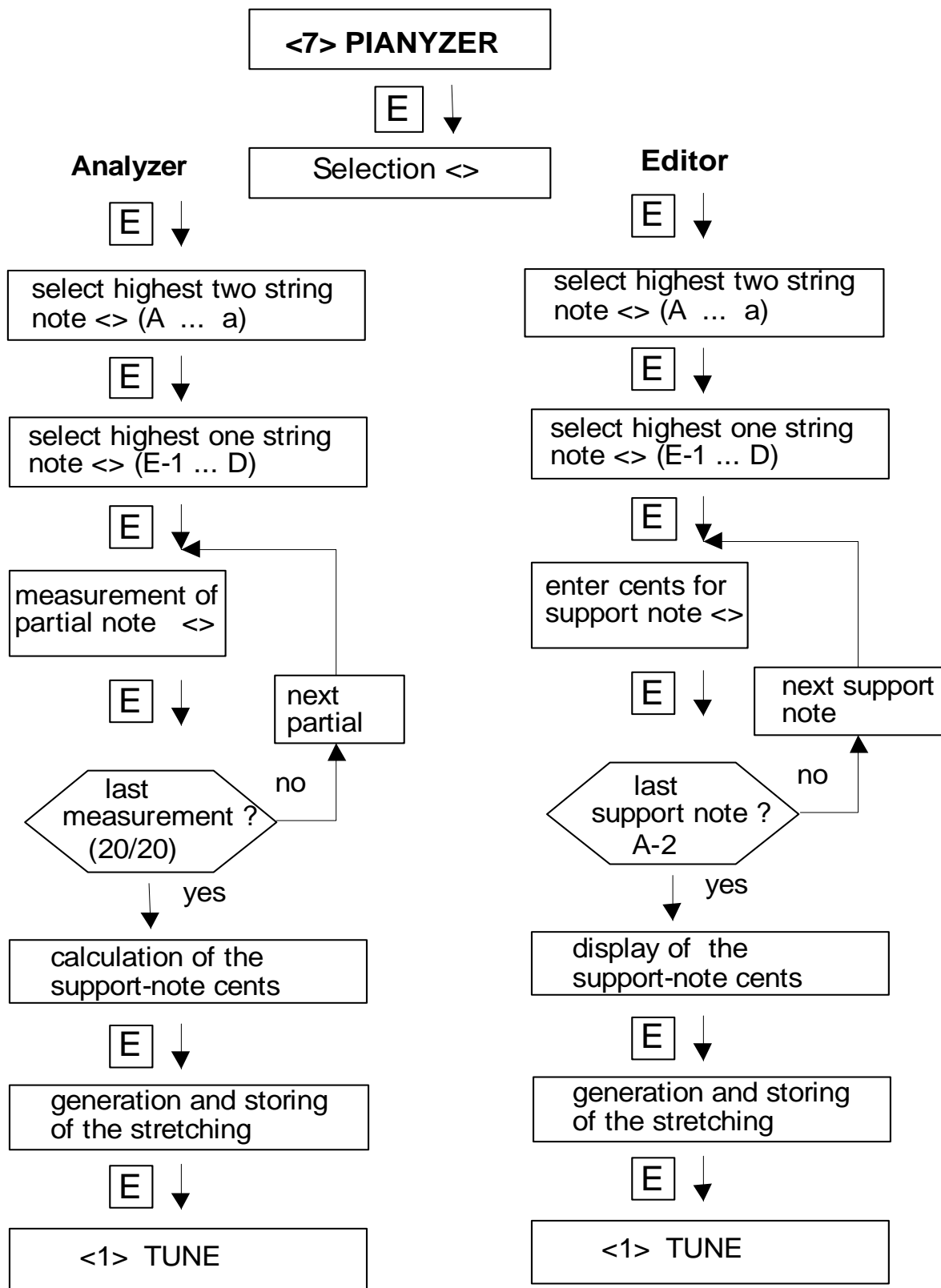

S + **E**

Holding "S"-key pressed while tapping "E"-key leads to back step or program abort

3.7 Special settings

In the same way that a language can be selected, it is possible to change some other attributes of the set, so that you can optimize the CTS-5-C for your application. The settings will be permanently stored, even if the device is switched off. Operate as follows:

1. Switch off the device.
2. Hold key "A" pressed while switching on the device, and keep it pressed until the following display appears:

```
ILLUMINATION
on
```

With „< >“ you may switch the illumination on or off.

Press „E“.

With "< >" you adjust the timer switch on or off.

```
TIMER
on
```

On: The device automatically turns off after 15 Minutes without operation.

Off: The device will not be turned off by timer.

Press „E“.

With "< >" you may select a mode number. This mode will be selected immediately after turning the unit.

```
FIRST MODE
1 TUNE
```

Press "E", the settings will be stored, and the device turns into normal operation.

4 Technical data Tuning Set CTS-5-C

Tuning Range:

8 octaves

Via fundamental tone A to g#-5 (110 to 6644,9 Hz)

Via 2nd harmonic A-1 to G# (55 to 103,8 Hz)

Via 4th harmonic A to G#-1 (27,5 to 51,9 Hz)

Tuning Deviaton Display:

1. electronic strobo display for fine tuning;
2. Good/bad indicator 4 cent
3. Bargraph on the LC-Display
3. Digital +/- 99.9 cent on cent measure mode.

Accuracy: Absolute and relative 1/10 cent (1/1000 semi-tone)

Operating Range: 0 to 40 ° Centigrade

Temperaments

- | | | |
|----------------------|----------------------|----------------------|
| 1. Equal Temperament | 11. Neidhard (1724) | 21. Silbermann_I |
| 2. Bach/Barnes, | 12. Neidhard (1729) | 22. Silbermann_II |
| 3. Bach/Kellner | 13. Meantone | 23. Silberm/Billeter |
| 4. Bach/Schubiger | 14. Pytagoraen | 24. Valotti |
| 5. Bruder/P.Vier | 15. Rameau/Schugk | 25. Werckmeister_III |
| 6. Kirnberger_I | 16. Rameau/Schubiger | 26. Werckmeister_IV |
| 7. Kirnberger_II | 16. Schlick_I | 27. Werckmeister_V |
| 8. Kirnberger_III | 17. Schlick/Billeter | 28. Memory |
| 9. Lambert/Schugk | 19. Schlick/Vogel | |
| 10. Lambert/Chaumont | 20. Silberm./P.Vier | |

Temperaments number 1... 27 are fixed stored, number 28 may be stored by the user.

Piano Stretchings:

1. very slight, 2. slight, 3. moderate, 4. pronounced, 5. memory)

The stretchings 1... 4 are fixed stored, number 28 may be stored by the user.

Concert Pitch a1:

Adjustable 380,0 Hz to 470,0 Hz in Steps of 0,1 Hz. Automatic tracing function.

LC-Display: 16 x 2 Char, illuminated.

Adjustable for English, German, French and Italian users.

Microphon:

Built-in condenser microphone and socket for external microphone or pickup (200...600 Ohm).

Audible tone:

Available in all tuning modes.

Power Supply

Mains adaptor or batteries (4 * Mignon 1.5 Volt) or rechargeable NiMh Batteries 4 * Mignon 1.2 Volt.

Data of Mains Adaptor:

7.5 Volts DC regulated, 400 mA. DIN coaxial plug 5*2mm, plus pole outside.

Internal Filter Circuit: Bandpass 64 dB per octave.

Dimensions and Weights: 125 x 97 x 50 mm / 230 g

T/A

www.tuning-set.de