

V 1.30

# *Manual*



***TUNING SET CTS-7-P***  
***TUNING SET CTS-7-PE***

E

**TLA**

engineering office for modern electronic design





# Overview for Menu Control TUNING SET CTS-7-P and CTS-7-PE

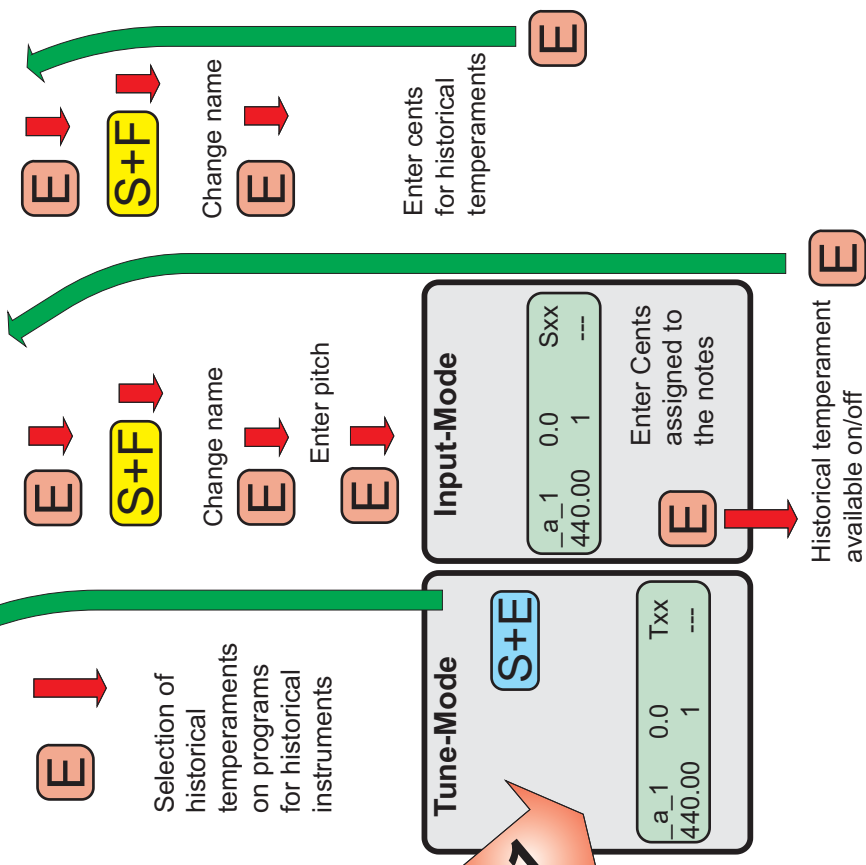
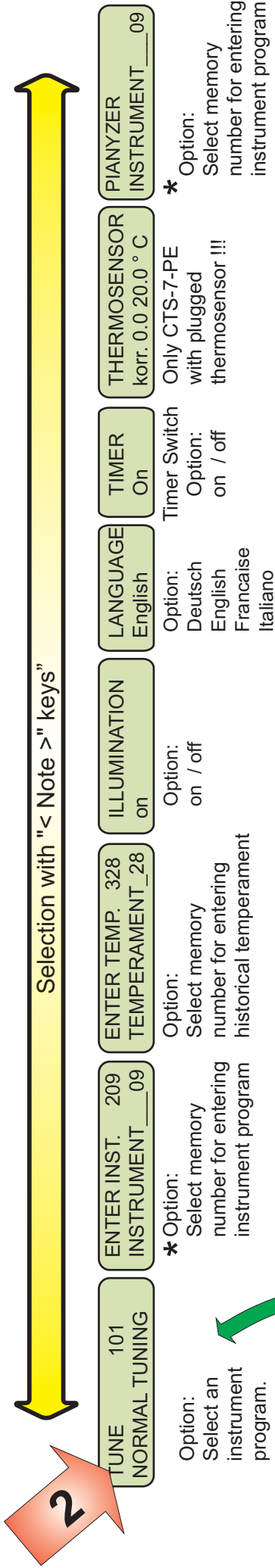

1 Directly after power on, at instrument program "normal tuning" the device immediately enters into tuning mode.

2 Directly after power on, at all other instrument programs, the device enters into menu control mode.

**How to operate the keys in menu control mode**

<Note>: Select menu  
 <Func>: Select option, assigned to the current menu.  
 E: Confirm the selected option.

**How to enter a name:**

<Note>: Cursorposition one digit left  
 Note>: Cursorposition one digit right  
 <Func>: Change char on cursorposition  
 S+<Note>: Clear char  
 S+Func>: Char on cursorposition = 'A'  
 S+<Func>: Char on Cursorposition = '0'

\* These modes are only available for instrument programs 9....60

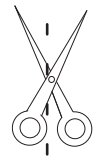

# Quick Reference for Tune Mode

## Tuning Set CTS-7-P and CTS-7-PE

**Strobe Display:**  
moving left: Tone too deep  
moving right: Tone too high

**LC-Display**

**Cent - Indication**

**"Note" Keys**  
Note -Adjustment:  
< lower one semi-tone  
> raise one semi-tone  
S+< lower one octave  
S+> raise one octave  
< +> search automatically

**TLA TUNING SET CTS-7-PE**

Note Cent Menu  
\_a\_1 0.0 T01  
440.00+ 1 ---

Pitch Partial Interval

**Indication of concert pitch**

**Indication of cent adjustment**

**Indication of note to be tuned**

**Indication adjustment of interval**

**Indication adjustment of partial tone**

**Key "F":**  
Function Selector  
(Indication with arrow)  
Concert pitch  
Cent  
Harmonic (Partial)  
Interval

**Key "S+F":**  
Audible tone on.  
Keys "S + F" again:  
Audible tone with higher volume.  
Keys "S + F" again:  
Audible tone off.

**Key "S+E" simultaneously:**  
Leave tune mode

**"Func" Keys:**  
Function Selector:  
Concert pitch: 220.00 ... 880.00 Hz  
Step 0.01 Hz (+S 0.1 Hz)  
Cent: -99.9 ... 99.9  
Step 0.1 Cent (+S 1 Cent)  
Partial (Partial) 1...8  
Interval:  
Second, Terce, Quinte, Septime  
Both keys simultaneously:  
search automatically (Cent or Pitch)  
Both keys simultaneously second times:  
Set pitch to 440.00 or  
Cents to 0.0

**Bargraph-Indication:**  
1. digit 1 Cent  
2. digit 2 Cent  
3. digit 4 Cent  
4. digit 8 Cent  
5. digit 16 Cent  
6. digit 32 Cent  
7. digit 64 Cent

**Key E:**  
Change between pitch-  
and bargraph indication

**Key "F":**  
Function Selector  
(Indication with arrow)  
Concert pitch  
Cent  
Harmonic (Partial)  
Interval

**Key "S+F":**  
Audible tone on.  
Keys "S + F" again:  
Audible tone with higher volume.  
Keys "S + F" again:  
Audible tone off.

**Key "S+E" simultaneously:**  
Leave tune mode

**"Func" Keys:**  
Function Selector:  
Concert pitch: 220.00 ... 880.00 Hz  
Step 0.01 Hz (+S 0.1 Hz)  
Cent: -99.9 ... 99.9  
Step 0.1 Cent (+S 1 Cent)  
Partial (Partial) 1...8  
Interval:  
Second, Terce, Quinte, Septime  
Both keys simultaneously:  
search automatically (Cent or Pitch)  
Both keys simultaneously second times:  
Set pitch to 440.00 or  
Cents to 0.0

**Bargraph-Indication:**  
1. digit 1 Cent  
2. digit 2 Cent  
3. digit 4 Cent  
4. digit 8 Cent  
5. digit 16 Cent  
6. digit 32 Cent  
7. digit 64 Cent

# Overview for Menu Control TUNING SET CTS-7-P and CTS-7-PE

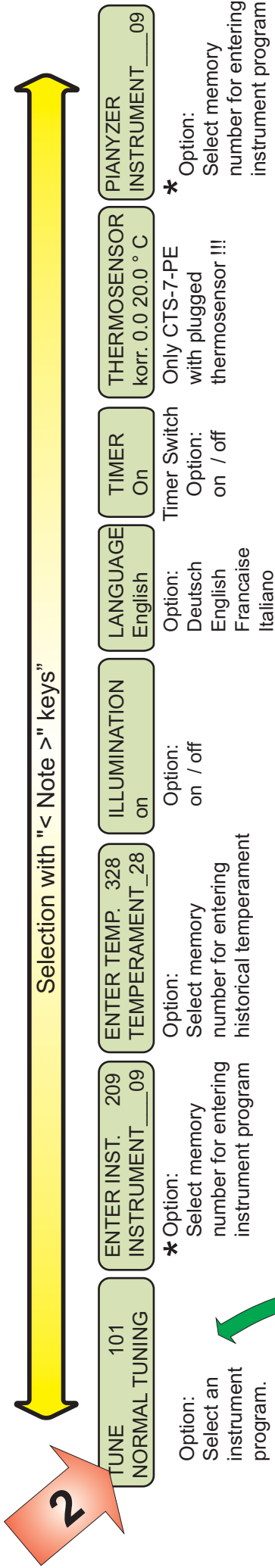

**1** Directly after power on, at instrument program "normal tuning" the device immediately enters into tuning mode.

**2** Directly after power on, at all other instrument programs, the device enters into menu control mode.

**How to operate the keys in menu control mode**

<Note>: Select menu  
 <Func>: Select option, assigned to the current menu.  
 E: Confirm the selected option.

**How to enter a name:**

<Note>: Cursorposition one digit left  
 Note>: Cursorposition one digit right  
 <Func>: Change char on cursorposition  
 S+<Note>: Clear char  
 S+Func>: Char on cursorposition = 'A'  
 S+<Func>: Char on Cursorposition = '0'

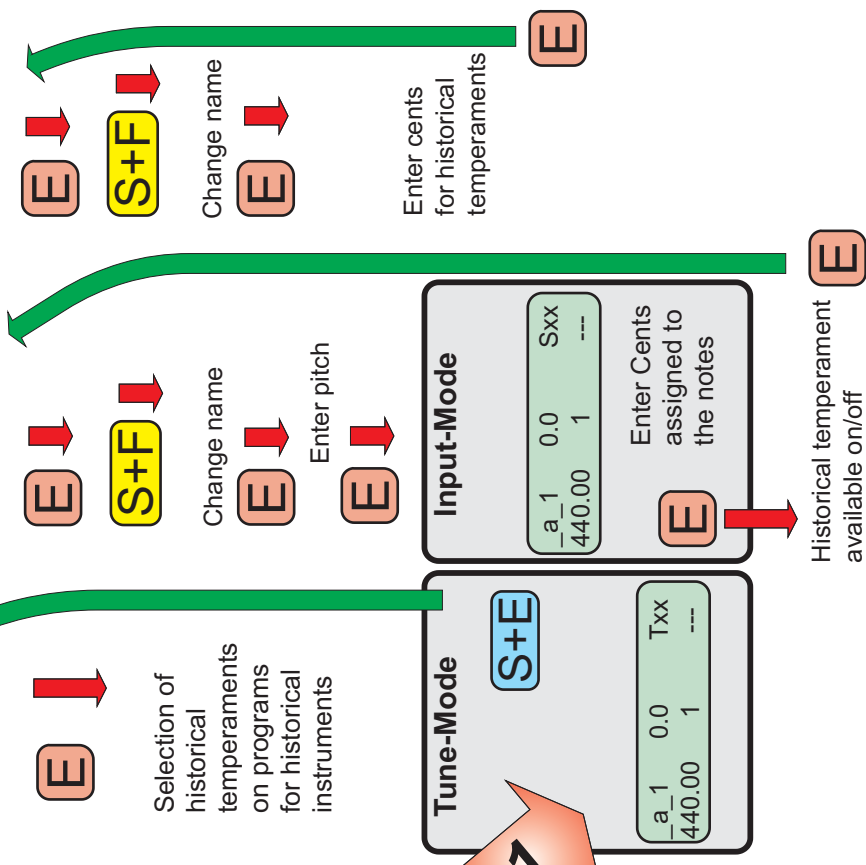

\* These modes are only available for instrument programs 9....60

# Switches and sockets

## CTS-7-P

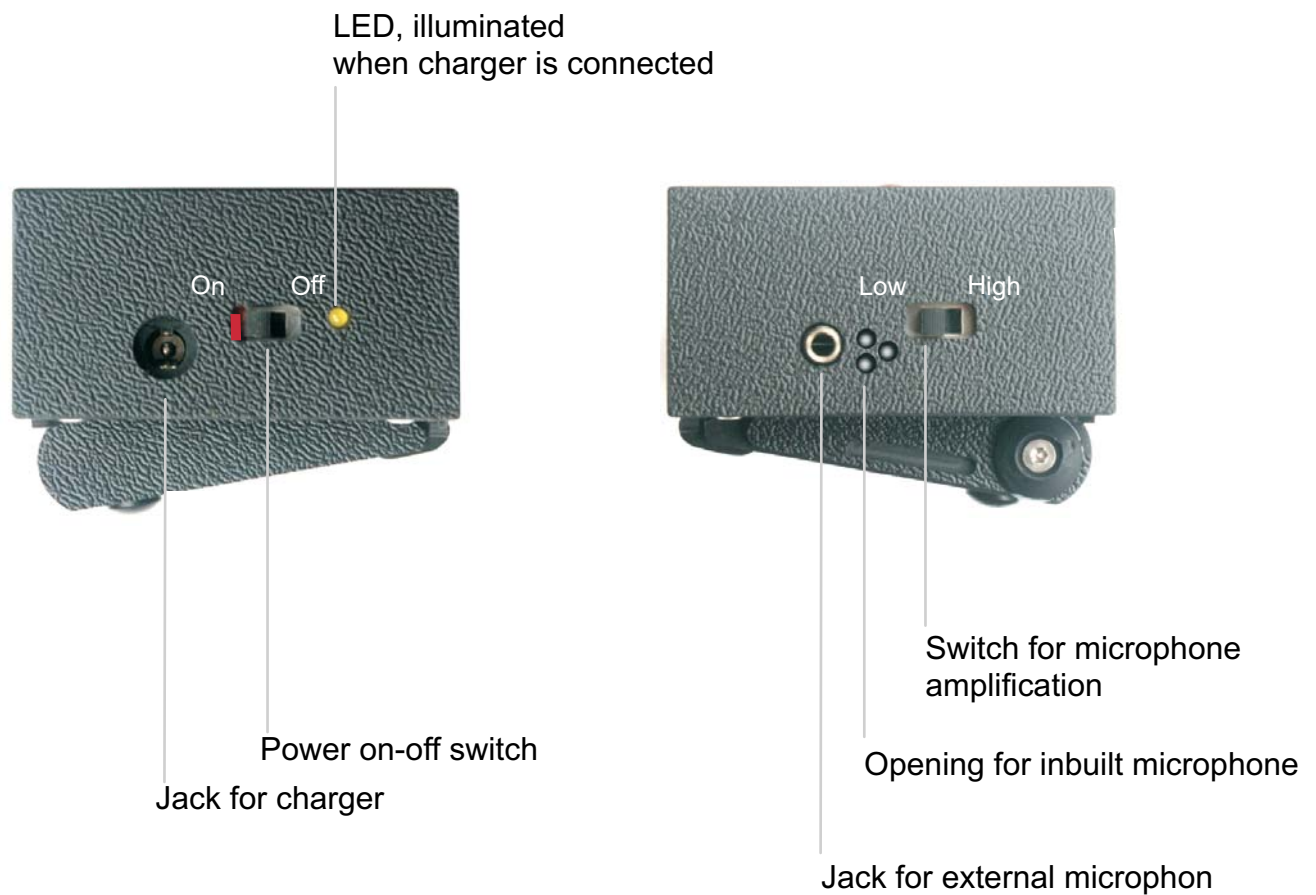

## CTS-7-PE

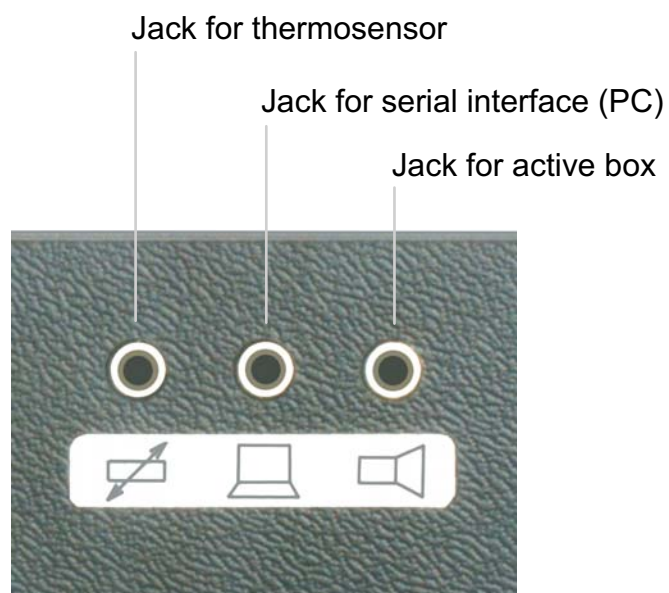

# Note Indication CTS-7

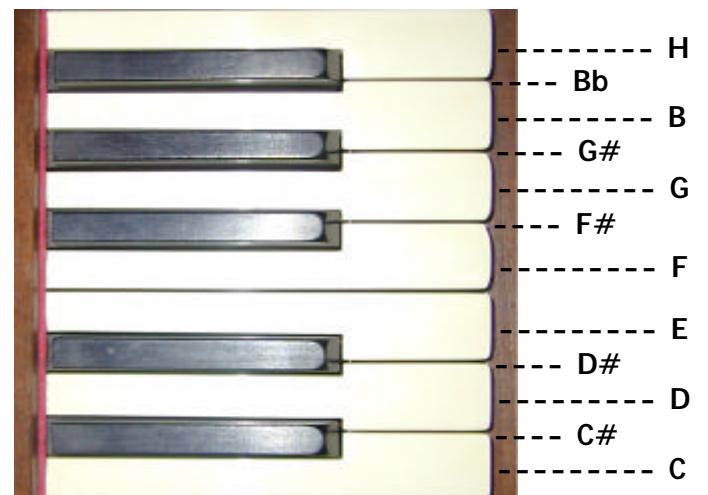
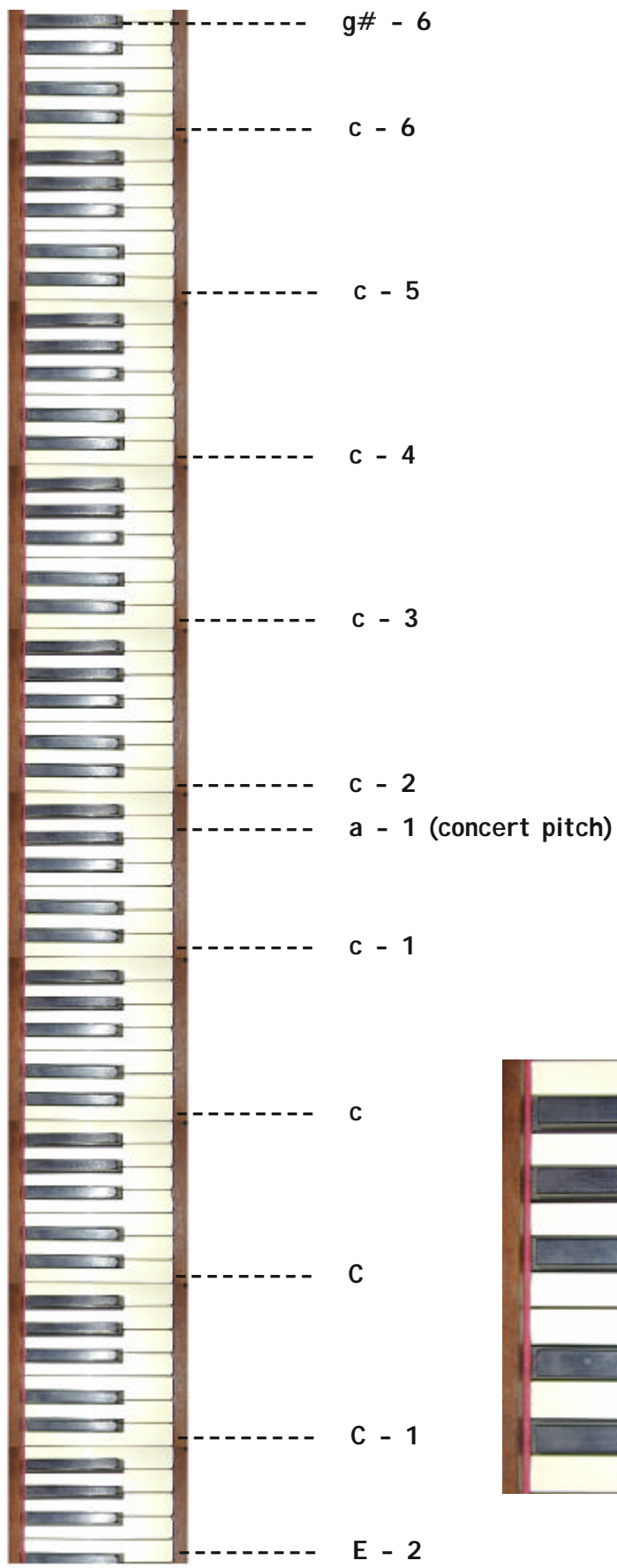



**TUNING SET CTS-7-P**  
**TUNING SET CTS-7-PE**

Congratulations to the purchase of your Tuning Set CTS-7. It will make the tuning of your musical instruments much easier and will provide you with high-precision results.

**Part 1** of these operating instructions contains general information about the Tuning Set.

**Part 2** allows you to learn the basic functions by means of operating examples. To quickly familiarize yourself with the Tuning Set, follow the examples with a musical instrument and the tuning device, and stick closely to the instructions. The “Quick Reference Guide for the Tuning Mode” contains a summary of the subjects of part 2 on one page.

The remaining chapters contain special subjects and examples for more in-depth study as needed. For orientation purposes, the “Menu Control Overview” is included in this manual.

**Contents**

**1 Initial Operations** ..... 3

1.1 Power supply ..... 3

1.2 Battery change ..... 3

1.3 Setting up the device ..... 4

1.4 Recording ..... 4

1.5 Active box for audible tone (CTS-7-PE only) ..... 4

1.6 Switching on the Tuning Set ..... 4

1.7 Resetting the device to factory settings ..... 4

1.8 Deleting all memories ..... 5

**2 Tuning Mode (Basic Tuning Functions)** ..... 5

2.1 Strobe display ..... 5

2.2 Bar graph display ..... 5

2.3 Audible tone on/off ..... 6

2.4 Tone adjustment ..... 6

    2.4.1 Automatic tone adjustment mode ..... 7

2.5 Selecting functions ..... 7

2.6 Pitch setting (concert pitch) ..... 7

    2.6.1 Automatic pitch search ..... 8

2.7 Cent adjustment ..... 8

    2.7.1 Automatic cent search ..... 9

2.8 Partial tone adjustment ..... 9

2.9 Pure interval tuning ..... 9

**3 Menu Control** ..... 9

3.1 Tuning Set switch-off ..... 11

3.2 Illumination on/off ..... 12

3.3	Automatic timer .....	12
3.4	Thermosensor calibration (CTS-7-PE only).....	12
3.5	Tuning pianos .....	12
3.6	Tuning historical instruments .....	13
3.7	Tuning guitars .....	13
3.8	Storing cent values of historical temperaments .....	13
3.9	Storing the entire tuning of an instrument .....	14
3.10	The PIANYZER, how to make individual piano tunings.....	16
3.10.1	How to create a stretching by the analysis of a piano (ANALYZER) .....	16
3.10.2	How to produce a stretching by entering of support values (Piano Editor).....	18
3.10.3	Diagram of an PIANYZER stretching .....	18
3.11	Tone sequences and automatic return .....	20
3.12	Tremolo tuning.....	20
3.13	Deleting a single instrument program .....	20
3.14	Copying an instrument program .....	20
3.15	Combining stretchings and temperaments .....	20
4	<i>The Serial Interface (CTS-7-PE only) .....</i>	21
4.1	Data transmission from and to a PC (CTS-7-PE only) .....	21
5	<i>Basic Information .....</i>	21
5.1	Equal temperament .....	21
5.2	The “cent” unit.....	21
5.3	The target frequency of the Tuning Set .....	22
5.4	Cent adjustment of historical temperaments .....	22
5.5	Cent reference function.....	22
5.6	Transposer .....	23
5.7	Stretchings .....	23
5.8	Thermosensor rate .....	23
5.9	Thermosensor reference.....	24
5.10	Filtering of partials .....	24
5.11	Limitation of values .....	24
6	<i>Technical Data .....</i>	25

# 1 Initial Operations

## 1.1 Power supply

The Tuning Set is equipped with 4 rechargeable NiMH batteries (1.2 Volt 2000 mAh). The operating period with one battery charge lasts approx. 12 hours. When the batteries are low, the indicator "LOW BAT" appears in the LC-display. In order to avoid deep discharge of the batteries, the device will automatically shut off. The battery can be recharged with the supplied plug-in transformer. The batteries are fully recharged after approx. 14 hours. When the plug-in transformer is connected, the yellow charge control LED is lit. When the batteries are fully charged, the transformer will not automatically shut down. Therefore, the tuning device should be disconnected after the charge. The instrument can be operated without risk during the recharging process.

Should the operating period with one battery charge decrease at some point to much less than 8 hours, the following may have occurred:

1. The battery set is defect. Measure to be taken: Install new batteries.
2. The plug-in transformer is defect. Measure to be taken: Replace the transformer. (7.5 Volt (min) 360 mA DC stabilized, hollow plug 5 x 2 mm plus outside)
3. The Tuning Set is defect. Measure to be taken: The charger and Tuning Set should be sent in for maintenance.

If you constantly use the device with the plug-in transformer connected, it is advisable to remove the batteries to avoid permanent-charging damage.

## 1.2 Battery change



Remove back cover.



Remove battery with a small screwdriver.

When replacing the batteries, it is important to ensure correct polarity.

### 1.3 Setting up the device

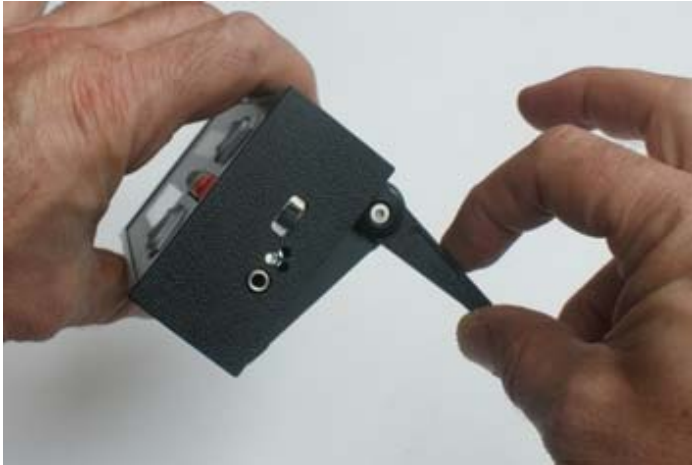

### 1.4 Recording

Recording takes place by means of a built-in condenser microphone on the right side of the tuning device. An external microphone jack (3.5 mm) can be plugged into the socket, also found on the right-hand side of the device. This deactivates the internal microphone.

You can adjust the sensitivity of the built-in microphone with the slide switch (high/low) located on the right side of the Tuning Set. You may need this especially for the low tones of a piano. The optimal setting of this switch and the optimal placement of the Tuning Set must be found during the tuning process.

### 1.5 Active box for audible tone (CTS-7-PE only)

You can raise the volume of the audible tone by plugging an active box with a 3.5 mm jack (available at computer shops) into the socket located on the backside of the set.

### 1.6 Switching on the Tuning Set

Turn on the Tuning Set with the slide switch on its right-hand side. For approximately one second you see the program version, and then the following indication appears:

Note	Cent	Menu
_a_1	0.0	T01
440.00 ←	1	---

Should another indicator appear, please reset the Tuning Set to factory settings (see next paragraph)

Pitch      Partial      Interval

### 1.7 Resetting the device to factory settings

Selecting the wrong key or mode will not damage the Tuning Set. The permanently stored temperaments and stretchings cannot be erased or changed by pressing a wrong key (exception see chapter 1.8). In order to become acquainted with the Tuning Set, you may play and experiment with the keys as much as you wish. Should you have stumbled in your first "walking trials" and programmed a non-desired setting, you can always return to the original settings and reset the Tuning Set as follows:

1. Switch off the device.
2. While pressing the keys "F" and "E" simultaneously, switch on the device.
3. Keep the keys pressed until this display is indicated.
4. Let go of the keys.
5. Select your language with the "Func" keys and confirm with the "E" key.
6. After ca.10 seconds this display will be indicated.  
Resetting CTS-7 was successful and the set is now in the tuning mode.

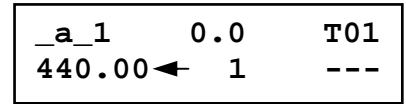
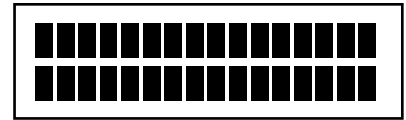

## 1.8 Deleting all memories

**!!! Attention: all your data will be lost !!!**

Clear all memories and reset the device to delivery status:

1. Switch off the device.
2. While pressing the keys "F" and "E" simultaneously, switch on the device.
3. Immediately after that tap „S“ key four times in quick succession.
4. Select your language with the "Func" keys and confirm with the "E" key.

## 2 Tuning Mode (Basic Tuning Functions)

The basic tuning functions are summarized in the "Quick Reference Guide for the Tuning Mode". To become well familiar with the Tuning Set, follow the operating examples below on a musical instrument and stick closely to the instructions.

### 2.1 Strobe display

Strike the tone a1 on your instrument. Two fields of green light will appear in the strobe display.

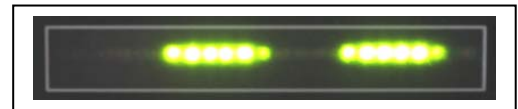

When the played tone is too low or too high, these fields move to the left or right accordingly. When the tone comes closer to its target value, the movement becomes slower. Once the tone is correct, the fields stop moving.

You can recognize large frequency deviations, when one of the two green dots on the left or right of the strobe display is lit. Depending on whether the tone being tuned is too high or too low, either the right or the left dot will be lit continuously. If neither of these two dots shine, the tone played is at the desired pitch of +/- 4 cent. If a strobe field moves across the display once in 20 seconds, the frequency deviation is 0,1 Hertz.

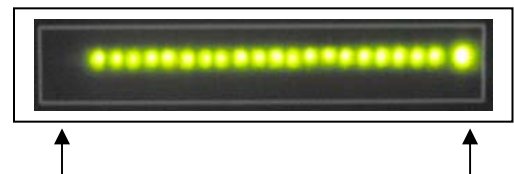

### 2.2 Bar graph display

In the tuning mode, you can switch between the bar graph and the concert pitch display with the "E" key.

Press the "E" key. When you now strike the tone a1 on your instrument, the arrow points to the right, if the tone played is too high, and to the left, if it is too low.

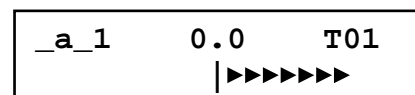

## Out of tune (frequency deviation)

1. Field > 1 cent
2. Field > 2 cent
3. Field > 4 cent
4. Field > 8 cent
5. Field > 16 cent
6. Field > 32 cent
7. Field > 64 cent
8. Field >128 cent

Press key "E" again and the set will switch back to the pitch display.

_a_1	0.0	T01
440.00←	1	---

## 2.3 Audible tone on/off

- Activate tone: When you keep the "S" key pressed and tap "F", you will hear the tone at the currently desired frequency. Release both keys.
- Deactivate tone: Keep "S" key pressed and tap "F" again.
- Increase volume: While keeping "S" pressed, press "F" twice again for higher volume.

Keep the audible tone activated for the following examples.

## 2.4 Tone adjustment

In the tuning mode, the two "Note" keys are used to adjust the tone.

When you start the process, this appears on the display:

_a_1	0.0	T01
440.00←	1	---

Tap "Note >" key - this raises CTS-7 by one semitone.

_b_1	0.0	T01
440.00←	1	---

Tap "< Note" key - this lowers CTS-7 by one semitone.

_a_1	0.0	T01
440.00←	1	--

Keeping the "S" key pressed and simultaneously tapping the "Note >" key briefly, will raise CTS-7 by one octave.

_a_2	0.0	T01
440.00←	1	---

Keeping the "S" key pressed and tapping the "<Note" key briefly, will lower CTS-7 by one octave.

_a_1	0.0	T01
440.00←	1	---

Deactivate the audible tone now.

### 2.4.1 Automatic tone adjustment mode

When both “Note” keys are pressed simultaneously, switching to another tone occurs automatically from this point on. The device automatically follows the tone level of the played tone.

The activated automatic tone adjustment mode is indicated by the rectangle shown by the arrow.

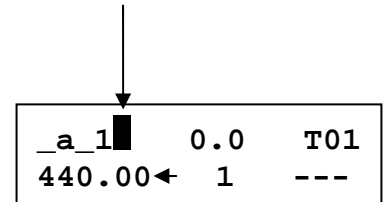

Tip: The automated switching was intentionally limited to 12 semitone steps around the played tune, to avoid tuning in the wrong octave.

Pressing both “Note” keys simultaneously will deactivate the auto mode again.

## 2.5 Selecting functions

By using the two “Func” keys, you can change the following values:

1. Concert pitch
2. Cent
3. Partial
4. Interval

Using the “F” key, you can select the “Func” key’s assignment to one of the above functions.

After switching on the Tuning Set:

The left-pointing arrow is now to the right of the pitch indicator. By tapping one of the “Func” keys you can change the concert pitch.

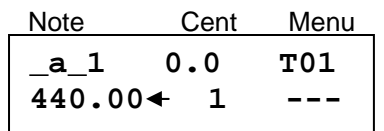

Now press the “F” key. From this point on, the “Func” keys are used for cent adjustment. The left-pointing arrow is now to the right of the cent indicator.

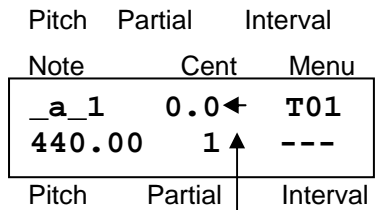

Now press the “F” key again. From this point on, the “Func” keys are used for partial tone adjustment. The left-pointing arrow is now to the right of the partial indicator.

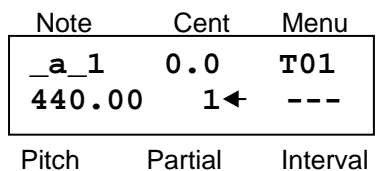

Now press the “F” key again. From this point on, the “Func” keys are used for interval adjustment. The left-pointing arrow is now to the right of the interval indicator.

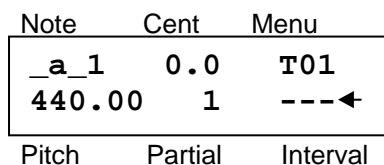

Pressing the “F” key again returns the “Func” keys to the concert pitch adjustment again.

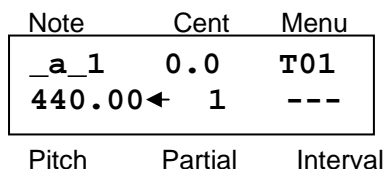

## 2.6 Pitch setting (concert pitch)

The concert pitch is the principal reference tone on which the entire tonal system of the tuning device is based. It is linked to the note a1 (a') and is adjustable from 220 to 880 Hz in steps of 0.01Hz.

By tapping the "Func >" key, you can raise the standard pitch by 1/100th Hertz.

_a_1	0.0	T01
440.01←	1	---

By tapping the "< Func" key, you can lower the standard pitch by 1/100th Hertz.

_a_1	0.0	T01
440.00←	1	---

If you continually press the "S" key and simultaneously tap the "Func>" key, you will raise the standard pitch by 0.1 Hz.

_a_1	0.0	T01
440.10←	1	---

If you continually press the "S" key and simultaneously tap the "<Func" key, you will lower the standard pitch by 0.1 Hz.

_a_1	0.0	T01
440.00←	1	---

### 2.6.1 Automatic pitch search

If both "< Func" and "Func >" keys are pressed simultaneously, the concert pitch of the Tuning Set begins to move automatically to the pitch being played at that moment (auto pitch mode).

_a_1	0.0	T01
438.19█	1	---

When the pitch is found, the auto pitch mode will be deactivated and the left-pointing arrow is indicated again.

This mode is indicated by the rectangle on the right side of the cent display.

_a_1	0.0	T01
417.11←	1	---

Watch the strobe. If it is still moving, adjust the Tuning Set to the correct tone, by tapping the keys "< func" or "func >" repeatedly, until the stroboscopic display stands still while the tone is being played. Only then, the set is adjusted to the desired and highly precise value.

## 2.7 Cent adjustment

The cent calibration is adjustable by  $\pm 99.9$  cents in steps of 0.1 cent. The unit of measure "cent" is used in acoustics for the deviation of a tone from a basic frequency. A cent is about one hundredth of a semitone step. The mathematical definition is described in chapter 5.2.

Select the function "cent adjustment" with the "F" key as described in chapter 2.5.

_a_1	0.0←	T01
440.00	1	---

By tapping the „Func >“ key, you can raise the cent calibration by 0.1 cent.

_a_1	0.1←	T01
440.00	1	---

By tapping the „< Func“ key, you can lower the cent calibration by 0.1 cent.

_a_1	0.0←	T01
440.00	1	---

If you press the "S" key and simultaneously tap the "Func >" key, you will raise the cent calibration by one cent.

_a_1	1.0←	T01
440.00	1	---

By pressing the "S" key and simultaneously tapping the "< Func" key, you will lower the cent calibration by one cent.

_a_1	0.0←	T01
440.00	1	---



### 2.7.1 Automatic cent search

If both keys “< Func“ and “Func >“ are pressed simultaneously, and you are playing the tone a\_1, the cent calibration of the Tuning Set begins to move automatically to the tone played on your instrument at the moment (auto cent search mode).

This mode is indicated by the rectangle on the right-hand side of the cent indicator.

When the correct cent value is found, the auto search mode is deactivated and the left-pointing arrow is indicated again.

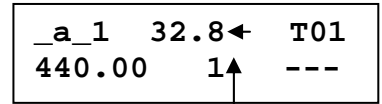
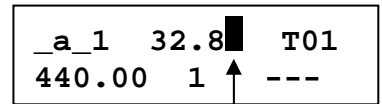

Watch the strobe. If it is still moving, adjust the Tuning Set to the correct tone, by tapping the keys "< func" or "func >", until the strobe display stands still while the tone is being played. Only then, the set is adjusted to the correct value.

### 2.8 Partial tone adjustment

Normally, a tone is composed of several partials, also called harmonics. The fundamental (1. partial) defines the base pitch. The second partial is one octave above the fundamental, the third partial relates with a 1:3 ratio to the fundamental, the fourth 1:4 etc.

Normally, measurements occur based on the fundamental (1. partial). For particularly low notes or tones with a weak fundamental wave, it may be useful to do the tuning with a higher partial for a better indication.

For partial tone adjustment, find the function selection for partials with the “F” key as described in chapter 2.5.

Using the “Func“ keys, you can adjust partials 1 thru 8.

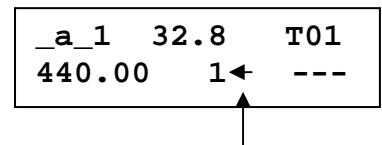

### 2.9 Pure interval tuning

For organ builders, the device includes a feature for the tuning of pure intervals.

For interval adjustment, find the function selection for partials with the “F” key, as described in chapter 2.5.

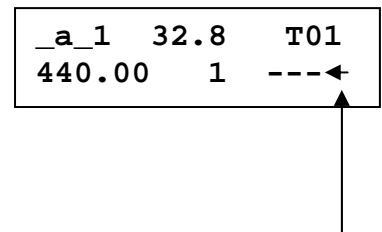

With the “Func“ keys you can enter the following adjustments:

SEK:	Second	8:9
TER:	Third	4:5
QUI:	Fifth	2:3
SEP:	Seventh	4:7

### 3 Menu Control

With the different keys, you can find your way through the included “Menu Control Overview”, like on a 'road map'. Don't try to memorize the key sequences in the examples. Simply try to understand the operation scheme of the Tuning Set by following the examples in the overview.

In order to be able to follow the next examples, the display should indicate the following:

If this is not the case, reset the device as described in capter 1.7.

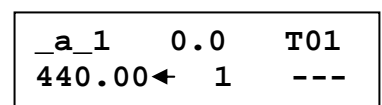

You are now at the position shown by the big arrow number 1 in the "Menu Control Overview".

Continually press the "S" key and simultaneously tap "E" key (from here on we will call this key combination "S+E").

The Tuning Set now leaves the tuning mode. In the menu, you are moving to the top (highest level of the menu control).

To avoid confusion, the different menu points are marked. This menu mark will appear where it is possible.

Now press "E", and you will move back to the bottom of the menu. The Tuning Set is operating in the tuning mode again.

Press "S+E" again. The set leaves the tuning mode again. Now, in the menu, you are at the highest menu control level again.

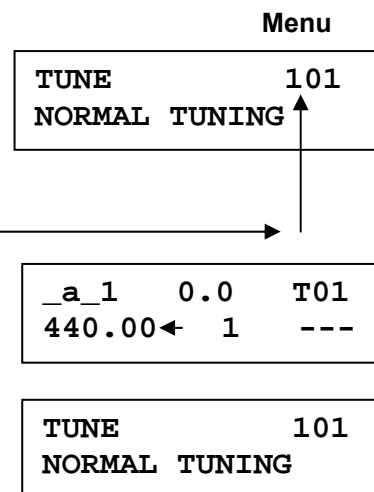

With the "Note" keys, you select one of the following applications:

- TUNE
- ENTER INST. (only for instrument program 9 ... 60)
- ENTER TEMP.
- ILLUMINATION
- LANGUAGE
- TIMER
- TH.SENSOR (CTS-7-PE only, with themosensor connected)
- PIANYZER (only for instrument program 9 ... 60)

With the "E" key, you confirm the application in order to move to the next step. The "Func" keys are assigned to the bottom line of the display.

The following table provides an overview of the connection between menu structure and key operation.

<b>Selection "Note"</b>	<b>Selection "Func"</b>	<b>Comment</b>
TUNE	Selection, one of 60 instrument programs	Select the music instrument to be tuned
ENTER INST.	Selection of an instrument program 9 until 60	Select a memory number to enter a instrument program
ENTER TEMP.	Selection of one memory from 28 bis 80	Select a memory number to enter a historical temperament
ILLUMINATION	ON / OFF	Illumination on or off
LANGUAGE	Deutsch, English, Francaise, Italiano	Select your language
TIMER	ON / OFF	On: Device switches off after 15 minutes, when not in use
TH.SENSOR	Enter a correction value for the connected themosensor	Only available when sensor is connected
PIANYZER	Selection of an instrument program 9 until 60	Select a memory number to enter a instrument program See section 3.10

With the "Note >" key, you can move to the right in the menu.

ENTER INST.	209
INSTRUMENT	__09

With the "<Note" key, you can move back to the left.

TUNE	101
NORMAL TUNING	

Now, press the "Func>" key. With this, you can select, for example, an instrument program which contains a piano tuning. (Detailed description how to tune pianos is in chapter 3.5.)

TUNE	102
PIANO_STRETCH_1	

For example, if you intend to tune a harpsichord, you tap the "Func >" key several times, until this indicator appears:

TUNE	105
HARPSICHORD	

Now press "E".

Using the "Func" keys, you now can select one of 80 different historical temperaments.

TEMPERAMENT R01	
EQUAL_TEMPERMT	

Tap the "Func >" key several times, until this indicator appears:

TEMPERAMENT R07	
KIRNBERGER_II	

Remark: The last two digits of the menu mark contain the memory number of the temperament.

Press "E". Using the "Func" keys, you now can select the cent-reference tone for the temperament (cent reference see chapter 5.5).

CENT-REF.	X00
_A_	

Press "E" again. Using the "Func" keys you now transpose the temperament into another key (transposer see chapter 5.6)

TRANSPOSER	Y00
_A_ ---> _A_	

Press "E" again. The set is operating in the tuning mode.

_a_1	0.0	T05
440.00←	1	---

Press "Note >" in order to raise the tone adjustment by one semitone step. The cent adjustment for the tone "b" now corresponds to that of the temperament "KIRNBERER-II". This way, the cents for every tone of the historical temperament will be indicated.

bb_1	1.0	T05
440.00←	1	---

Now, press "S+E". The Tuning Set will leave the tuning mode and return back to the highest menu control level.

TUNE	105
HARPSICHORD	

### 3.1 Tuning Set switch-off

You may simply turn off the device with the slide switch on the left side while in any of the applications. Applications in which cents are being stored, should be left by pressing "S+E" before turning the device off, in order to store the last adjustments.

If the instrument program 1 (Normal Tuning) was active before switch-off, the device enters into tuning mode immediately after being turned back on (overview: arrow 1). In all other cases, the device will be at the highest menu control level after being turned back on (overview: arrow 2).

### 3.2 Illumination on/off

Find this indicator on the display as described in chapter 0:  
Now, using the “Func“ keys, you can turn the illumination on or off.

ILLUMINATION	400
on	

### 3.3 Automatic timer

Find this indicator on the display as described in chapter 0:  
The timer function can be turned on or off with the “Func“ keys.

TIMER	600
on	

A timer was installed in the Tuning Set, to save battery power.  
If you don't use the set for fifteen minutes, it automatically turns itself off.

Before shut-down, it will set off short acoustic signals for about 30 seconds. This allows you to prevent shut-down by pressing any of the seven keys. If the Tuning Set automatically shuts down, you can restart it with the on/off switch on the right side by switching it off and then on again.

### 3.4 Thermosensor calibration (CTS-7-PE only)

This menu serves to calibrate the thermosensor input for a thermosensor available as accessory for the CTS-7-PE. The menu point is available only when a sensor is actually connected to the device.

The thermosensor controls the target frequency of the set in relation to the measured room temperature.  
See chapters 3.9., 5.4 and 5.9.

THERMOSENSOR
corr. 1.0 18.4°C

For calibration, find this display indicator as described in chapter 0:

On the right side you see the room temperature measured by the sensor.  
On the left there is an offset value that is added to the indicated temperature.

The offset can now be adjusted until the indicated temperature corresponds to the actual room temperature. When leaving this function, the calibration offset value is stored.

### 3.5 Tuning pianos

First things first: One cannot overemphasize the fact that piano tuning requires experience. If it is done without the necessary knowledge and skills, the piano may be irreparably damaged. In one tuning, a piano should never be raised or lowered by more than 30 cent.

When tuning instruments with thick strings such as pianos and grand pianos, “stretching” the tuning becomes necessary. This implies that, different from the standard tuning mode, the high tones must be tuned higher and the low tones lower. We will discuss this further in chapter 5.7 of this Manual.

The permanently stored instrument programs “PIANO\_STRETCH\_1 to 3” are considering this by using inharmonicity curves. That is, a cent value is given for each tone, which shows the offset of the piano tuning from the equally tempered tuning.

For these tone-stretching tasks, each of the 60 instrument programs possesses a memory space for each tone capable of registering a deviation of up to  $\pm 99,9$  cent per tone.

The selection of the optimal stretching depends on various parameters of the instrument to be tuned. Individual preferences of the musician also play a vital role. Three permanently-stored instrument programs are available in the CTS-7-P (PE). You may store the temperaments of up to 51 pianos in the CTS-7-P (PE). Using the „PIANYZER“ you can create special stretchings suitable to individual instruments (see section 3.10).

The three built-in stretchings found in the system are the result of trials, during which various pianos were tuned by ear, and subsequently measured. You must try out the stretching most suited to match your particular requirements first. For your first attempts, we recommend that you try the Piano Stretch 3. For this please apply the following:

Find this display indicator as described in chapter 0:

TUNE	104
PIANO STRETCH	3

Press "E":

_a_1	0.0	T04
440.00←	1	---

First, it is useful to define the current concert pitch of the instrument (see chapter 2.6.).

Then enter the desired concert pitch tone into the device. When applying this function, the new concert pitch should be no more than 10 Hz higher than the former pitch, in order to avoid warping of the instrument or tearing strings during the tuning task.

You may now begin with the actual tuning by starting with the tone a-1 and aligning all 3 strings of the chorus. Next follows g#-1, g1, f#-1, etc.

The cent indicator shows the deviation from the standard tuning caused by tone stretching.

_c_1	-0.9	T04
440.00←	1	---

For the two lowest octaves, the partial mode changes to the second or the fourth partial. This way, you normally have a better indication when tuning a piano. For this reason, it is very important that the Tuning Set always has the correct octave setting. The best way to avoid inaccurate settings is to progress in steps of semitones while tuning the instrument.

G#_	-5.0	T04
440.00←	2	---

After finishing the tuning of the bass, the discant is tuned by starting with b-1 upwards.

### 3.6 Tuning historical instruments

When using one of these instrument programs, you can select a historical temperament before entering the tuning mode:

"HARPSICORD", "ORGAN", or "HISTORICAL"

### 3.7 Tuning guitars

For guitar tuning, use the instrument program "GUITAR".

Here you only can access the 6 notes e, a, d1, g1 and h1 of the guitar strings.

### 3.8 Storing cent values of historical temperaments

A historical temperament relates only to the 12 chromatic semitones of an octave, and therefore only contains one cent value per semitone as a deviation from the equally tempered tuning. This line of cent values is then repeated for each octave, considering that the cent deviation for the tone "a", as program-necessitated, is always zero. (See cent reference function and transposition in chapter 5.5 and 5.6)

In the Tuning Set CTS-7-P(PE) there is memory space for 80 temperaments. Number 1 thru number 27 are allocated to permanently stored temperaments. You may enter temperaments number 28 to number 80.

In this example we enter temperament number 30.

ENTER TEMP.	328
TEMPERAMENT	28

Find this display indicator as described in chapter 0:

Using the "Func" keys, search memory 30:

ENTER TEMP	330
TEMPERAMENT	30

Now, press the “E” key. On the display appears a moving line: “Go ahead with “S+F !“. To go ahead, keep “S” pressed and tap “F” (This acts as a memory protection).

Now, this is indicated on the display:

```
*
TEMPERAMENT__30
```

You now may assign an easily remembered name to the memory. In the “Menu Control Overview“ (lower right hand side) you will find a quick reference how to enter a name. In this example we will name the temperament: „TEST\_\_\_\_\_30“.

For this, press the “Note >“ key twice.

```
*
TEMPERAMENT__30
```

Tap the “Func >“ key several times, until this indicator appears:

```
*
TESPERAMENT__30
```

Press the “Note >“ key once. After that, tap the “Func >“ key several times, until this indicator appears on the display:

```
*
TESTERAMENT__30
```

Press the Note >“ key once. After that, hold key “S” pressed and tap the “Note >“ key until this indicator appears on the display:

```
*
TEST_____30
```

Now, confirm the input with “E“ key. You will receive the indicator for note “Bb” (Note “A” is automatically assigned 0.0 cent)

```
Bb_      0.0
```

Now, using the “Func“ keys, you may enter the cents assigned to note „Bb“.

```
Bb_      3.8
```

With “Note >“ key you switch to the next semitone. There you may enter the cents assigned to note “\_B“.

```
_B_      -5.3
```

This allows you to enter all values for the 12 chromatic semitones. After entering, confirm with the key “E”, and your data will be stored. The data may subsequently be changed again at any time.

At this point, you surely wish to tune your instrument using the stored temperament! So, find, as described in chapter 0, one of the instrument programs “HARPSICORD“, “ORGAN“ or “HISTORICAL“.

```
TUNE      105
HARPSICORD
```

Aside from the permanently stored temperaments, here you will find the temperament you have entered as number 30.

```
TEMPERAMENT R30
TEST_____30
```

### 3.9 Storing the entire tuning of an instrument

If you wish to store an already existing tuning of a whole musical instrument, for example a piano, you must create an instrument program. It may also be beneficial to create an instrument program, just to store a particular device adjustment.

In order to produce an instrument program, find as described in chapter 3.0 this indicator on the display:

```
ENTER INST. 209
INSTRUMENT  09
```

Using the “Func” keys, find, for example, memory number 14 (the last two digits of the menu indication correspond to the memory number). You can access memory number 9 thru 60.

```
ENTER INST.    214
INSTRUMENT    __14
```

Now, press the “E” key. On the bottom line of the display a moving line appears: “Go ahead with “S+F” !“. To go ahead, keep “S” pressed and tap “F” (for memory protection). This indicator appears on the display:

```
*
INSTRUMENT    __14
```

You now may assign an easily remembered name to the memory.

In the “Menu Control Overview “ (lower right hand side) you will find a quick reference how to enter a name. In this example we want to change “INSTRUMENT 14” to “PIANO\_\_\_\_\_14”.

Tap the “Func >“ key several times, until this indicator appears:

```
*
PIASTRUMENT   __14
```

Press the “Note >“ key once. After that, tap the “Func >“ key several times, until this indicator appears on the display:

```
*
PIASTRUMENT   __14
```

Press “Note >“ once. After that, hold “S” key pressed and tap “Func >“ key once, until this indicator appears on the display:

```
*
PIANTRUMENT   __14
```

Press “Note >“ once, after that, tap the “Func >“ key several times, until this indicator appears on the display:

```
*
PIANORUMENT   __14
```

Press “Note >“ once. After that, keep the “S” key pressed and tap the “Note >“ key several times, until this indicator appears on the display:

```
*
PIANO_____14
```

Confirm the operation by pressing key “E”.

You will see this indicator. Now play the note “a-1” on your music instrument and align the pitch adjustment of the Tuning Set to this tone until the strobe is standing still (see capter 2.6).

```
_a_1          P14
440.00←
```

Press the “E” key. The standard pitch will be stored to the instrument program, the Tuning Set enters the input mode.

```
_a_1    0.0←  S14
         1    ---
```

Press the ”Note >“ key to raise the set by one semitone. Play this tone on your instrument and align the Tuning Set’s cent adjustment until the strobe is standing still (see chapter 2.7)

```
bb_1    3.8←  S14
         1    ---
```

At the next change of tone this cent adjustment will be stored. Proceeding like this, store all cent values of your instrument’s tones.

For particularly low tones or tones with a weak fundamental wave, it may be useful to do the tuning with a higher partial (see chapter 2.8). This adjustment will also be stored at the next change of tone. Using the “F” key, you can change between cent and partial adjustment.

You may access already stored values for “cent” and “partial” any time with the “Note” keys, for verification or correction.

When you have stored all the tones of your instrument, confirm this by pressing the “E” key. This indicator appears:

```
store with    E
back with    < >
```

By pressing any key except “E“, you may again go back to the input mode. Press the “E” key again.

At this point, setting the option "Hist.Temperament" to "on", will allow you to select an historical temperament before entering the tuning mode. Press the "E" key.

```
Hist. Temperament
off
```

Only if there is a thermosensor connected to the Tuning Set, you are asked to enter the next two items.

*Using the "func" keys, enter the room temperature at which you expect the tuning of your music instrument to be (simply the temperature at the time you have stored the cent values).*

```
th.sensor offset
20.0 deg.centig
```

*Press key "E" again. Using the "func" keys, enter a cent value, corresponding to the pitch difference of your music instrument when the room temperature rises by 1 degree centigrade.*

```
th.sensor rate
0.0 cent/celsi
```

*To confirm press key "E".*

You instrument program will now be stored.

```
ENTER INST.    214
PIANO_____  14
```

You surely intend to tune your instrument using the stored instrument program! So please find your instrument program, as described in chapter 0.

```
TUNE           214
PIANO_____  14
```

By pressing key "E" you enter into the tuning mode. The concert pitch will be shown. When tapping the "Note" keys, you will find the cent values in the cent-indicator.

```
_a_1    0.0    T14
440.00← 1     ---
```

### 3.10 The PIANYZER, how to make individual piano tunings.

Using the „Pianyzzer“ (Piano Analyzer) you get more beautiful piano tunings. Here the stretching of the instrument will be optimized individually.

In the same way as you can store instrument tunings, this stretching is also stored. So you may save 50 of them.

The stretching can be created in two ways.

1. By an analysis of the piano to be tuned (ANALYZER).
2. By entering cents for certain specific tones (EDITOR).

#### 3.10.1 How to create a stretching by the analysis of a piano (ANALYZER)

If you have practiced, you need for the analysis less than 5 minutes. Due to the interference-free analog strobe display you get a safe, reproducible result.

By measuring the cent-deviation of certain partials of 5 special tones, reference values are determined. (See the sample diagram of an individual piano stretching at the end of this chapter). Based on these support-values, an optimized stretching will be calculated and stored. To this end, the device makes all settings automatically. Important! For all measurements, please damp with a felt wedge the string chorus so, that sounds just one string.

To work with the Analyzer, do the following:

After switching on the unit, look for an unused instrument program i.e. „INSTRUMENT\_\_\_10“. There you search the option "PIANYZER" using the "note" keys“

```
TUNE           ->110
INSTRUMENT___ 10
```

After pressing the key "E", keep the die „S“ button pressed while at the same time tapping "F" button, to skip the write protection.

```
PIANYZER       ->110
INSTRUMENT___ 10
```



Select the option „ANALYZER“ and press „E“ again.

```
SELECT      A10
ANALYZER <>
```

Select the highest tone of your piano which has a 2 string chorus and press “E”.

```
_d_ <> S10
2-STRING CHOIR
```

Select the highest tone of your piano which has a 1 string chorus and press “E”.

```
_G#_ <> S10
1-STRING CHOIR
```

Play the note "a-1" to measure the concert pitch of your instrument and use the "Func" buttons to align the tuner. (See also chapter 2.6 of the manual) or you already can tune the chorus of "a-1" to your desired pitch.

```
_a_1      K10
440.00 ←
```

By pressing the "E" you are starting with the measurement of the individual partials of the piano-analysis. The indicator for this is structured as follows:

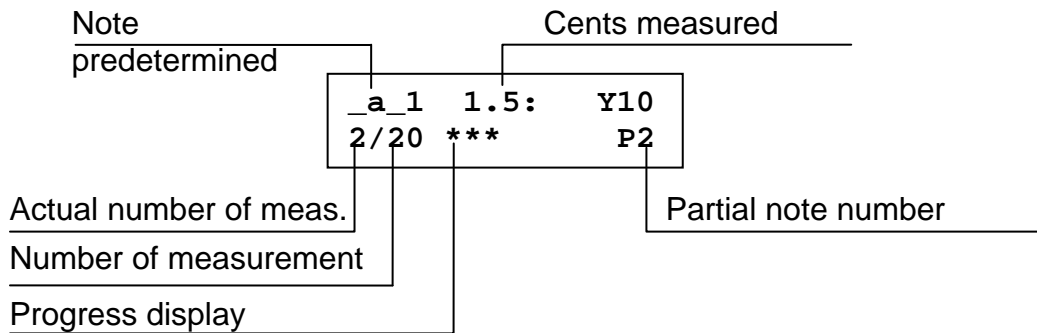

Start now with the measurements (you now measure the second partial of a-1. To do this, play the note which is automatically adjusted by the tuner (right now a\_1) and align the tuners frequency until the movement of the strobo display is stopped.

For fine adjustment use the "Func" buttons. For rough adjustment, you hold the "S" button and tap one of the keys "Func". Pressing both buttons, "Value" at the same time, starts an automatic scan. The audible tone can be used also.

Press „E“.

Play the specified note (for the moment again a\_1, since you now measure the 3rd partial of a-1) and align the tuner again. Press “E”.

```
Cent
_a_1  3.5 ← Y10
3/20  **   P3
```

Play the specified note (for the moment again a\_1, since you now measure the 4rd partial of a-1) and align the tuner again. Then press “E”. The tuner will now continue to the next note. It then emits a short beep and for 1 second „next note“ is indicated on the display.

```
Cent
_a_1  6.0 ← Y10
4/20  *   P4
```

Play the specified note (for the moment again a\_2, since you now measure the fundamental tone of a-2) and align the tuner again. Press “E”.

```
Cent
_a_2  2.5 ← Y10
5/20  **** P1
```

Certainly, you now know how the device pretends the operating steps. Now perform all measurements.

Important note: When the instrument is grossly out of tune, immediately after the tuner changes the note, you should align the actual tone to the tuner using a tuning hammer. This is necessary because the inharmonicity of the piano string depends on its tension. This, however, only be carried out immediately after the change of tone. So just before the measurements 5 / 9 / 13 / and 17 /

After the last measurement you get this display. This are eight cents-values (support values), that were determined automatically on the basis of previous measurements.

```
-26 -16 -8 -2
  0  3 11 36
```

Press "E". The device calculates the piano stretching and stores them. To start with the real work of piano tuning, search the function "tune" with the "note" buttons. Then it goes on, as described in Section 3.5 of the manual for CTS-7-P(PE)

TUNE	->110
INSTRUMENT	10

Note: Within the "PIANYZER"- procedure, you can back step using the "Note" buttons.

### 3.10.2 How to produce a stretching by entering of support values (Piano Editor)

The tones with the cent's for calculating the stretching, the sake of simplicity, will be referred to as "support note". Using the piano editor, the cents of the support-notes, you can enter by hand, rather than be determined by the analyzer (see sample diagram at the end of the chapter).

Note: The piano editor allows you to edit the cents of the supporting notes, which were previously generated by the piano analyzer.

To work with the Editor, do the following:

After switching on the unit, look for an unused instrument program i.e. „INSTRUMENT\_\_\_10“. There you search the option "PIANYZER" using the "note" keys“

TUNE	->110
INSTRUMENT___	10

After pressing the key "E", keep the die „S“ button pressed while at the same time tapping "F" button, to skip the write protection.

PIANYZER	->110
INSTRUMENT___	10

Select the option „EDITOR“ using the "func" keys and press „E“ again.

SELECT	A10
EDITOR	<>

Select the highest tone of your piano which has a 2 string chorus and press "E".

_d_	<>	S10
2-STRING CHOIR		

Select the highest tone of your piano which has a 1 string chorus and press "E".

_G#_	<>	S10
1-STRING CHOIR		

Play the note "a-1" to measure the concert pitch of your instrument and use the "Func" buttons to align the tuner. (See also capter 2.6 of the manual) or you already can tune the chorus of "a-1" to your desired pitch.

_a_1	K10
440.00	←

By pressing the "E " you are starting to enter the cents of the "support notes.

Using the „Func“ keys, you enter the Cents of the „support-note“ which is predefined by the tuner. With the „E“or „< Note“ key you may switch to the next „support-note“. With „Note >“ key you can back step.

_a_2	3.0	←	E10
SUPPORT-NOTE 6			

If you have entered the cents for all the "support-notes" , you will get i.e. the following indicator.

-26	-16	-8	-2
0	3	11	36

Press "E". The device calculates the piano stretching and stores them. To start with the real work of piano tuning, search the function "tune" with the "note" buttons. Then it goes on, as described in Section 3.5 of the manual for CTS-7-P(PE).

TUNE	->110
INSTRUMENT	10

### 3.10.3 Diagram of an PIANYZER stretching

... see next page.

# Diagram of a piano stretching that was generated with the Pianyzer

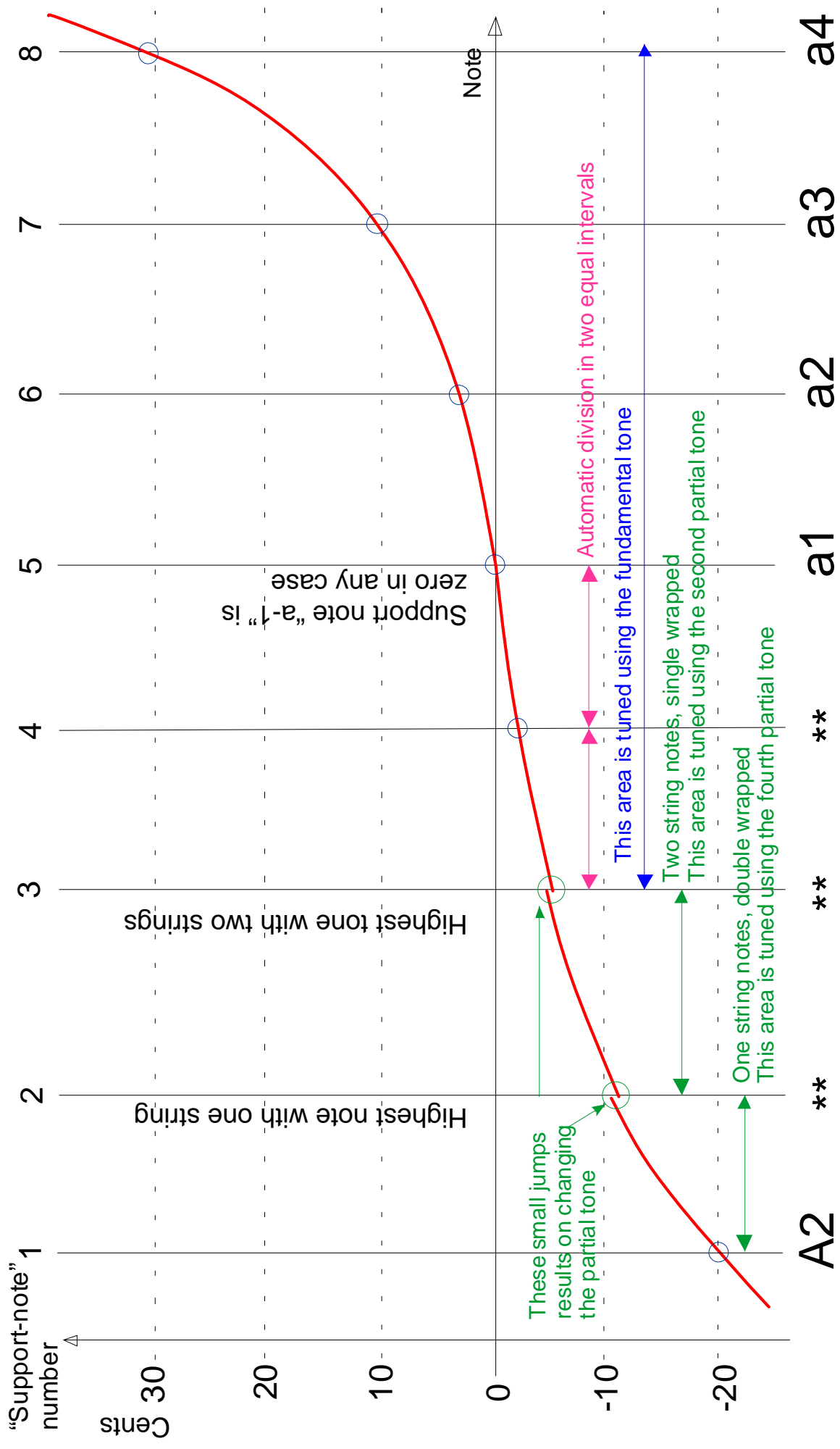

\*\*These "support-notes" depends on the way of the strings arrangement

### 3.11 Tone sequences and automatic return

For instrument programming, the functionality of the partial adjustments was expanded: In addition to the values "1" thru "8", you may enter the value „0,, and the character „\*,,.

Meaning:

„0,, In the tuning mode, the tone adjustment will skip any tone with this partial adjustment.

„\*,, This character can be assigned to two different tones only. When entering the tuning mode, the tone adjustment will automatically jump to the lower of the two. When you reach the higher one, the tone adjustment automatically will jump back to the deeper one.

This function enables the tuning of diatonic music instruments with a small tone range.

Remark: When entering data containing the sign „\*,, into a PC, it will be changed to "-1".

### 3.12 Tremolo tuning

This feature supports operations by enabling fast changes between two instrument programs.

For tremolo tuning, you may use two instrument programs which succeed one another. The first of the two gets a stretching for the deeper tones of the tremolo. The second gets a stretching for the higher tones of the tremolo. In the tuning mode you may change between the two, i.e., you can quickly raise the instrument program number by pressing key "func >" and "note >" simultaneously. You can lower it by pressing key "< func" and "< note" simultaneously.

### 3.13 Deleting a single instrument program

For example, if you wish to delete the instrument program "PIANO\_\_\_\_\_14" again, which you have produced in example 3.9, find the following indicator, as described in chapter 3.

ENTER INST.	214
PIANO_____	14

Tap both "func" keys twice in fast succession. After that, keep the "S" key pressed and tap the "F" key. The instrument program will thus be erased.

ENTER INST.	214
INSTRUMENT_____	14

### 3.14 Copying an instrument program

Select a program memory space in which you intend to store your copy (see chapter 3.9). Instead of overwriting the instrument program's name, tap the "S+F" key again.

"COPY INSTRUMENT" is now indicated on display's upper line. Using the "func" keys, you can select the instrument program you intend to copy (its name is indicated on the display's lower line). By tapping the "E" key, you confirm the operation and the instrument program is copied.

### 3.15 Combining stretchings and temperaments

To refresh your already considerable knowledge of the Tuning Set:

Each of the 80 instrument programs contains memory space for one stretching. Stretchings are functions that encompass the entire tone range of an instrument. For each tone (spanning its entire range) there is a cent value in the Tuning Set. One stretching therefore contains storage space for a total of  $9.5 \cdot 12 = 114$  cent values. One stretching can be stored for each instrument program.

On the other hand, a temperament relates only to the 12 semitones of an octave, and therefore only contains 12 cent values. These cent values are then repeated for each octave, considering that the cent deviation for the tone "a", as program-necessitated, is always zero (see Cent reference function and Transposer in chapter 5.5 and 5.6). You may enter 80 such temperaments into the device.

You can combine all stored stretchings with the historical temperaments as you please. If you select a temperament and a stretching at the same time, the Tuning-Set will add the temperament cents to those of the stretching.

## 4 The Serial Interface (CTS-7-PE only)

### 4.1 Data transmission from and to a PC (CTS-7-PE only)

All data which you have stored in the Tuning Set CTS-7-PE can be transmitted to a PC and retrieved from it again, or transmitted to another device.

You can download (free of charge) the needed interface software for the PC from the internet (<http://www.tuning-set.de>) or from the supplied CD. There you will also find a detailed description of the interface software and its use.

Any terminal program can also be used for data transmission. To operate with a terminal program, use the description of this program and the description of the protocol for serial interface of CTS-7-PE, which is also available for download from internet or from the CD.

## 5 Basic Information

### 5.1 Equal temperament

The standard tuning of the Tuning Set is the most frequently used equal temperament. The following example shows exactly how it is conceived mathematically:

Target value: the concert pitch a' should be 440,00 Hertz

The frequency of the chromatic semitone steps are calculated accordingly:

$$\begin{aligned} b' &= 440,00 \text{ Hz} * \sqrt[12]{2} = 466,16 \text{ Hz} & \sqrt[12]{2} &= 1,0594631 \\ h' &= 466,16 \text{ Hz} * \sqrt[12]{2} = 493,88 \text{ Hz} & & \text{etc.} \end{aligned}$$

Target value: the concert pitch a' should be 442,00 Hertz

The result would be:

$$\begin{aligned} b' &= 442,00 \text{ Hz} * \sqrt[12]{2} = 468,28 \text{ Hz} \\ h' &= 468,28 \text{ Hz} * \sqrt[12]{2} = 496,13 \text{ Hz} & \text{etc.} \end{aligned}$$

### 5.2 The "cent" unit

The "cent" is a unit for frequency relations; a semitone step is divided geometrically into 100 parts. The following calculation demonstrates how the "cent" unit is mathematically defined:

The frequency 440.00 Hertz are to be raised by 1 cent:

$$440.00 \text{ Hz} * \sqrt[1200]{2} = 440,26 \text{ Hz}$$

The frequency 440.00 Hertz are to be raised by 5 cent:

$$440.00 \text{ Hz} * \sqrt[1200/5]{2} = 441.27 \text{ Hz}$$

The frequency 440.00 Hertz are to be raised by 100 cent, which means by one semitone:

$$440.00 \text{ Hz} * \sqrt[1200/100]{2} = 440.00 \text{ Hz} * \sqrt[12]{2} = 466.16 \text{ Hz}$$

The frequency 466,16 Hertz are to be lowered by 100 cent, which means by one semitone:

$$466.16 \text{ Hz} : \sqrt[1200/100]{2} = 466.16 \text{ Hz} : \sqrt[12]{2} = 440.00 \text{ Hz}$$

### 5.3 The target frequency of the Tuning Set

The microprocessor installed in the Tuning Set creates the target frequency as shown in the following equation:

$$f = \frac{k}{16} * 2^{o + \frac{n}{12} + \frac{c}{1200}}$$

Wherein:

- f: Target frequency
- c: Cent adjustment
- n: Tone number (a = 0, b = 1...gis = 11)
- k: Concert pitch setting (220 Hz... 880 Hz)
- o: Octave (1 = A-2(27,5 Hz)...9= a-5(7040 Hz)

### 5.4 Cent adjustment of historical temperaments

Please refer to the information as listed in the attached tabloid.

### 5.5 Cent reference function

All temperament tables pre-programmed in the tuning device are conceived to the effect that for the tone "a" the cent deviation equals zero. The cent reference therefore is "a". In some cases it is recommendable to adapt this cent reference to a tone other than "a". If a different tone is defined as cent reference for the tuning device, the cent values in the temperament tables are also raised or lowered by the same amount for each tone, with the result that the cent reference for that particular tone equals zero.

Example: cent deviations of the "Kirnberger III" temperament with the cent reference setting = "a" (standard case):

<b>a</b>	<b>b</b>	<b>h</b>	<b>c</b>	<b>c#</b>	<b>d</b>	<b>d#</b>	<b>e</b>	<b>f</b>	<b>f#</b>	<b>g</b>	<b>g#</b>
0	+6,5	-1,5	+10,5	+0,5	+3,5	+4,5	-3,5	+8,5	+0,5	+7,0	+2,5

For the cent reference setting = "c" 10,5 cent are subtracted from all above amounts:

<b>a</b>	<b>b</b>	<b>h</b>	<b>c</b>	<b>c#</b>	<b>d</b>	<b>d#</b>	<b>e</b>	<b>f</b>	<b>f#</b>	<b>g</b>	<b>g#</b>
-10,5	-4,0	-12,0	0	-10,0	-7,0	-6,0	-14,0	-2,0	-10,0	-3,5	-8,0

## 5.6 Transposer

The transposer allows the transposition of all temperament tables into another key system.

If for example the command transpose "a" to "c" ( A --> C) is entered, the cent values of the cent tables are transferred 3 semitones to the right. It should be noted, that the cent reference function also is in effect and the cent values of the tables are recalculated, so that for the cent reference tone the cent value is = 0.

Example: cent reference = "a" , transposes "a" to "c":

Original table of the Kirnberger-III temperament:

<b>a</b>	<b>b</b>	<b>h</b>	<b>c</b>	<b>c#</b>	<b>d</b>	<b>d#</b>	<b>e</b>	<b>f</b>	<b>f#</b>	<b>g</b>	<b>g#</b>
0	+6,5	-1,5	+10,5	+0,5	+3,5	+4,5	-3,5	+8,5	+0,5	+7,0	+2,5

First the table is transposed by 3 semitone steps to the right:

<b>a</b>	<b>b</b>	<b>h</b>	<b>c</b>	<b>c#</b>	<b>d</b>	<b>d#</b>	<b>e</b>	<b>f</b>	<b>f#</b>	<b>g</b>	<b>g#</b>
0,5	+7,0	+2,5	0	+6,5	-1,5	+10,5	+0,5	+3,5	+4,5	-3,5	+8,5

It is then recalculated to match the cent reference = "a" (-0,5 cent):

<b>a</b>	<b>b</b>	<b>h</b>	<b>c</b>	<b>c#</b>	<b>d</b>	<b>d#</b>	<b>e</b>	<b>f</b>	<b>f#</b>	<b>g</b>	<b>g#</b>
0	+6,5	+2,0	-0,5	+6,0	-2,0	+10,0	0	+3,0	+4,0	-4,0	+8,0

## 5.7 Stretchings

Striking a string on a piano produces a tone consisting of several harmonics (partials), which are not in tune with their fundamentals.

For example, the tone produced by a piano string for tone a' can consist of a 440 Hz fundamental, with a second harmonic at 881 Hz and a fourth harmonic at 1768 Hz. If the partials had a harmonic proportion of frequency to each other, the second harmonic would have a value of 880 Hertz and the fourth harmonic 1760 Hertz. However, in our example the second harmonic is one Hertz and the fourth harmonic 8 Hertz higher than demanded by theory.

This is known as the "inharmonic" of a piano string. It is caused by the flexural strength of the string and can be different from instrument to instrument. This inharmonicity explains why, on an upright piano or on a grand piano, the bass has to be tuned lower and the discant must be tuned higher.

The three different stretchings of the octaves pre-programmed in the Tuning Set were achieved through extensive test with various upright and grand pianos. The diagrams of these stretchings (PIANO\_STRETCH\_1 thru 3) are found on the last page.

In the lowest octave (A 2 to G#) the Tuning Set responds to the fourth harmonic, and in the octave (A 1 to g#) to the second harmonic. This is the reason for the two discontinuities in the beginning of the graphs.

To create individual stretchings we recommend the PIANYZER (see section 3.10).

You can combine the stretchings with temperaments as you please. If you select a temperament and a stretching at the same time, in the tuning mode, the Tuning-Set will add the temperament cents to those of the stretching.

## 5.8 Thermosensor rate

In this function, when a thermosensor is connected, one can adjust by how many cent per degree in Celsius the tone height is to be altered. Adjustable:  $\pm 5.0$  cent in steps of 1/10 cent.

## 5.9 Thermosensor reference

When a thermosensor is connected, this function allows the adjustment of the room temperature basis upon which the thermo sensor values are fixed.

**Example: Thermosensor reference = 20 °C Thermosensor rate = 0.2 cent/°C**

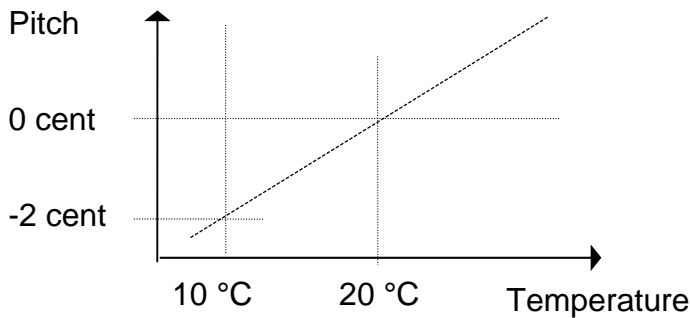

## 5.10 Filtering of partials

The low susceptibility to disturbance of the TLA Tuning Set display is achieved among other things through a band pass filter (64 dB per octave) installed in the device. This filter suppresses all in-coming signals of the microphone except the frequency of the tone to be tuned. Only the frequency of the partial, which is adjusted in the set, passes the filter. This makes it possible, for example, to measure the amplitude of individual partials selectively, i.e., the inharmonicity of a piano string.

Example: Filtering of the third partial

Filter input signal

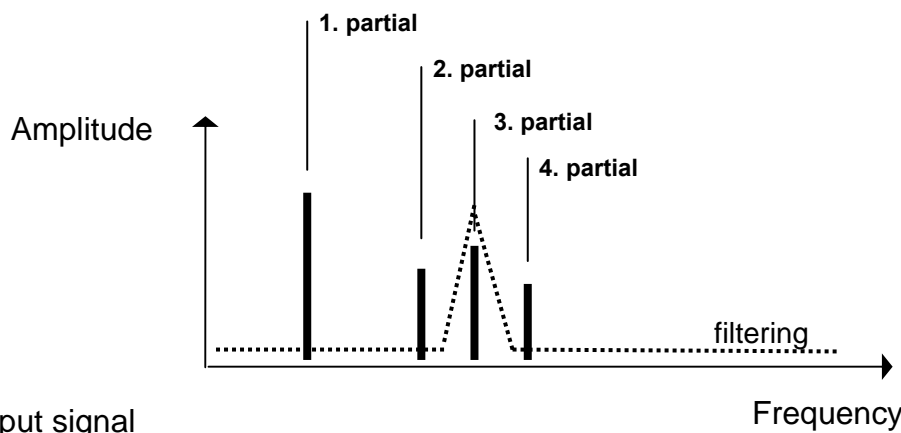

Filter output signal

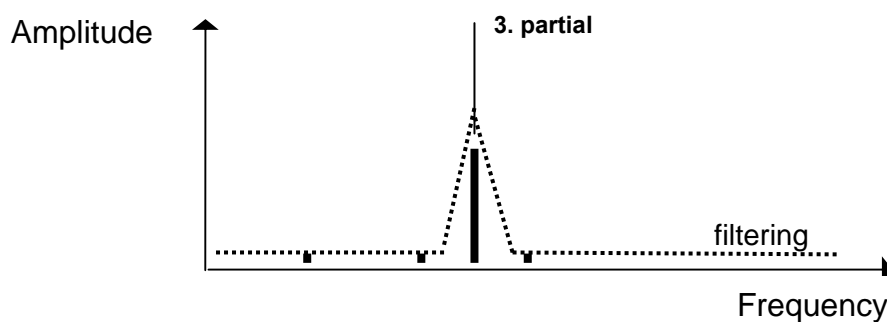

## 5.11 Limitation of values

The Tuning Set works in a frequency range of 20 Hz to 15000 Hz. All adjustments of tone, concert pitch, cent or partial with a frequency result outside this range, are suppressed.

For example, it is not possible to use the first partial on the deepest note „C<sub>2</sub>“ or to use the second partial of the highest note g#<sub>6</sub>.



## 6 Technical Data

**Tuning range:** 20 to 15,000 Hz (ca. 9,5 octaves)

**Accuracy of desired frequency:** absolute and relative < 0.1 cent (1/1000 semitone step!)

**Display:** 1. Analog, electronic stroboscope. 2. Bar graph 16 digit for 1 Cent 3. LED rough display:  $\pm 4$  cent

**Memory function for LCD-bar graph:** When the tone to be measured falls silent, the last measurement result is kept

**Concert pitch:** Adjustable from 220.00 to 880.00 Hertz in steps of 0.01 Hertz by tapping a key or using the automatic search function

**Adjustment of cents:** With keys  $\pm 99.9$  cent, in steps of 0.1 cent, or with the automatic search function or through the instrument program from memory

**Adjustment of purely tuned intervals:** Second, third, fifth, seventh

**Partial tone adjustment:** From 1. (fundamental) to 8th harmonic (partial) by key or instrument program

**Adjustment of microphone gain:** Two steps with slide switch

**Display:** High-contrast LC-display (super twist) with removable LED-background illumination

**Microphone:** Built-in condenser microphone and socket for external microphone 200 to 600 ohm

**Audible tone:** Available in tuning mode, adjustable in two volume steps, connector for PC active box (CTS-7-PE only)

**Thermo sensor input:** The cent rate for this input is adjustable in steps of 0.1 cent per degree in centigrade. The absolute temperature reference is adjustable in steps of 0.1 degree in centigrade.

**Serial interface (CTS-7-PE only):** 19200 baud, 7 data bits, 1 stop bit, parity: odd; protocol: Xon Xoff

**Historical Temperaments:** Memory for 80 temperaments. 52 temperaments may be programmed by the user himself and supplied with a 16-character name. The most frequently used temperaments (the first 27) are pre-installed in the delivered unit.

**Instrument programs:** Memory space for 60 instrument programs. Instrument programs for all standard instruments are already pre-installed in the unit. Each instrument program contains the following adjustment data:

*Name of instrument program (16 characters)*

*Memory available once for each tone in the instrument program (60x120 memory cells)*

- Cent memory  $\pm 99.9$  cent, to store stretchings, for example piano tunings (120 per instrument program)
- Memory for partials / harmonics: To select the harmonic for the measurement of each tone (120 per instrument program).

*Instrument program parameters:*

- Concert pitch
- Historical temperament
- Cent reference for the historical temperament
- Transposer for the historical temperament
- Thermosensor cent rate (CTS-7-PE)
- Thermosensor reference (CTS-7-PE)

**Filter circuit at the microphone input:** 64 dB per octave

**Pianyzer:** To create individual piano tunings.

**Power supply:** 4 \* Mignon NiMH battery, 1.2 volt /2000 mAh. Usable approx.12 hours with one charge. Time needed for recharging: 14 hours with plug-in transformer.

**Plug-in transformer:** 7.5V/300mA DC stabilized (hollow plug 5\*2mm, plus pole outside)

**Dimensions and weight:** 160 x 70 x 50 mm / 430g

## Cent-values of the historical temperaments

	A	B	Bb	C	C#	D	D#	E	F	F#	G	G#
1	EQUAL TEMPERAMENT	0,0	0,0	0,0	0,0	0,0	0,0	0,0	0,0	0,0	0,0	0,0
2	BACH/BARNES	0,0	6,0	0,0	6,0	2,0	4,0	-2,0	8,0	-2,0	4,0	2,0
3	BACH/KELLNER	0,0	4,0	-1,0	8,0	2,5	2,5	-2,5	6,0	-3,5	5,5	0,5
4	BACH/SCHUBIGER	0,0	2,9	-4,9	4,9	4,9	1,0	-4,9	4,9	-4,9	4,9	-1,0
5	BRUDER/P.VIER	0,0	1,0	-5,0	3,0	5,0	0,0	-6,0	2,0	-3,5	4,5	-1,0
6	KIRNBERGER_I	0,0	11,7	3,9	15,6	19,6	9,8	2,0	13,7	5,9	17,6	7,8
7	KIRNBERGER_II	0,0	1,0	-6,8	4,9	8,8	-1,0	-8,8	2,9	-4,9	6,9	-2,9
8	KIRNBERGER_III	0,0	6,4	-1,4	10,3	3,4	4,4	-3,4	8,3	-1,5	6,9	2,4
9	LAMBERT/SCHUGK	0,0	3,6	-2,8	4,2	1,4	1,7	-1,4	5,6	-4,2	2,8	-0,3
10	LAMBERT_CHAUMONT	0,0	7,8	-7,8	11,7	3,9	0,0	-3,9	15,6	-11,7	7,8	-19,6
11	NEIDHARD_(1724)	0,0	6,0	2,0	6,0	2,0	4,0	0,0	6,0	2,0	4,0	2,0
12	NEIDHARD_(1729)	0,0	3,9	2,0	5,9	2,0	3,9	0,0	3,9	2,0	3,9	2,0
13	MEANTONE	0,0	17,1	-6,8	10,3	3,5	20,6	-3,4	13,7	-10,2	6,9	-17,1
14	PYTAGORAEAN	0,0	-9,8	3,9	-5,9	-2,0	-11,7	2,0	-7,8	5,9	-3,9	9,8
15	RAMEAU/SCHUGK	0,0	8,0	-8,0	11,5	4,0	0,0	-4,0	15,5	-6,0	-8,0	-2,0
16	RAMEAU/SCHUBIGER	0,0	19,6	-7,8	11,7	3,9	7,8	-3,9	15,6	-5,9	7,8	-2,0
17	SCHLICK_I	0,0	7,8	-3,9	5,9	2,0	7,8	-2,0	7,8	-3,9	3,9	2,0
18	SCHLICK/BILLETER	0,0	10,1	-4,0	8,1	3,0	10,2	-1,9	9,9	-4,8	6,1	6,0
19	SCHLICK/VOGEL	0,0	9,0	-5,5	8,0	2,5	2,5	-3,0	11,0	-8,0	5,5	-4,5
20	SILBERM./P.VIER	0,0	6,0	-4,0	6,0	2,0	0,0	-2,0	8,0	-6,0	4,0	-2,0
21	SILBERMANN_I	0,0	10,8	-3,9	6,8	2,9	12,7	-2,0	8,8	-5,9	4,9	-9,8
22	SILBERMANN_II	0,0	8,1	-2,9	4,9	1,9	10,2	-0,9	7,1	-4,8	3,0	-7,9
23	SILBERM/BILLETER	0,0	10,8	-4,7	4,9	5,0	13,0	-5,0	8,2	-4,8	5,1	-11,0
24	VALOTTI	0,0	5,8	-3,9	5,8	2,0	3,9	-1,9	7,8	-1,9	3,9	1,9
25	WERCKMEISTER_III	0,0	8,0	4,0	12,0	4,0	6,0	2,0	10,0	0,0	8,0	4,0
26	WERCKMEISTER_IV	0,0	13,6	-3,9	9,7	5,8	3,8	2,0	7,7	-1,9	3,8	-5,9
27	WERCKMEISTER_V	0,0	1,9	-1,9	-0,1	3,9	-0,1	-3,9	3,9	0,1	1,9	-7,8

# Diagrams of piano stretchings

**PIANO STRETCH 1.**

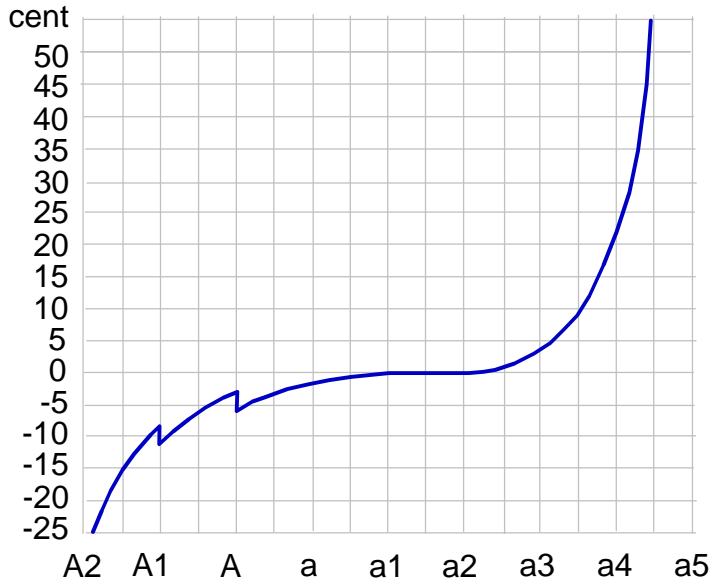

**PIANO STRETCH 2.**

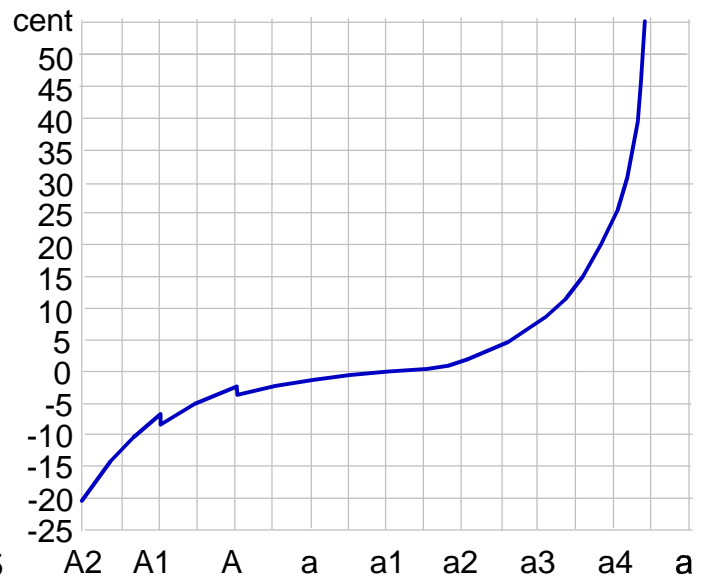

**PIANO STRETCH 3.**

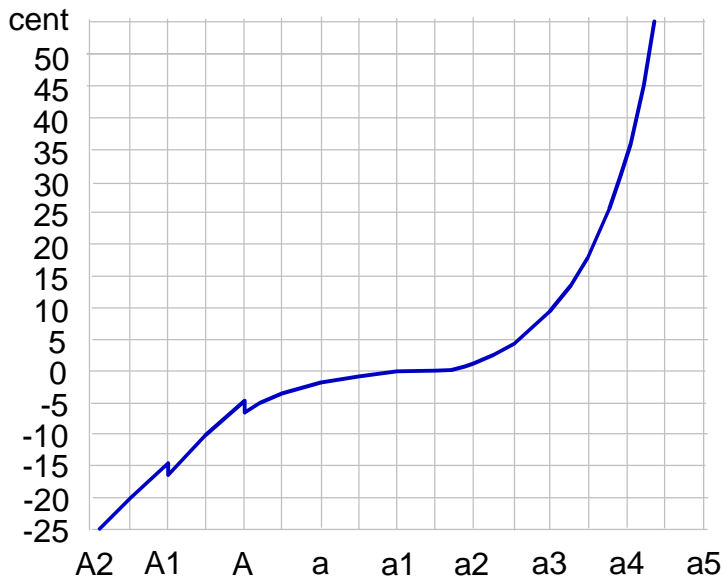

**T/A**

---

[www.tuning-set.de](http://www.tuning-set.de)